



# euspray®

by Eurospray spray and filter technology SL

## SELF CLEANING AND STATIC FILTERS CATALOGUE



# Cataloghi disponibili EUSPRAY

## EUSPRAY catalogues available

### Catálogos disponibles EUSPRAY

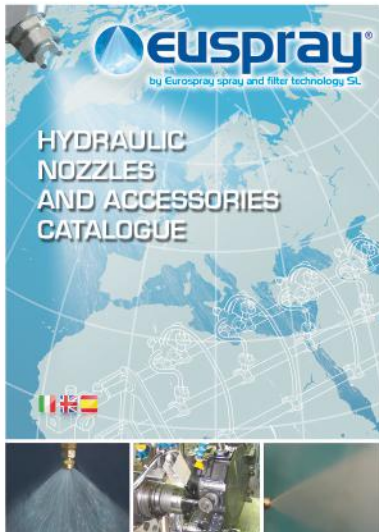

#### HOLLOW CONE NOZZLES



#### FULL CONE NOZZLES



#### FLAT SPRAY NOZZLES



#### ACCESSORIES



#### AIR ATOMIZING NOZZLES



#### HYDRAULIC ATOMIZERS NOZZLES



#### TANK CLEANING



## I SISTEMI DI FILTRAZIONE

p. 02

FILTERING SYSTEM  
LOS SISTEMAS DE FILTRACIÓN

## FILTRI AUTOPULENTI

p. 04

SELF-CLEANING SYSTEM  
FILTROS AUTOLIMPIANTES

### FILTRO HHF ALTISSIME PORTATE

HHF HIGHEST FLOW RATE FILTER  
FILTRO HHF CAUDAL MÁS ALTO

p. 06

### FILTRO LF BASSA PORTATA

LF LOW FLOW RATE FILTER  
FILTRO LF BAJO CAUDAL

p. 14

### FILTRO HF ALTA PORTATA

HF HIGH FLOW RATE FILTER  
FILTRO HF ALTO CAUDAL

p. 08

### FILTRO LF-LP BASSA PORTATA

LF-LP LOW FLOW RATE FILTER  
FILTRO LF-LP BAJO CAUDAL

p. 16

### FILTRO MF MEDIA PORTATA

MF MEDIUM FLOW RATE FILTER  
FILTRO MF MEDIO CAUDAL

p. 10

### FILTRO YLSAP MEDIA PORTATA

YLSAP MEDIUM FLOW RATE "Y" FILTER  
FILTRO YLSAP MEDIO CAUDAL

p. 18

### FILTRO MF-LP MEDIA PORTATA

MF-LP MEDIUM FLOW RATE FILTER  
FILTRO MF-LP MEDIO CAUDAL

p. 12

### FILTRO IN ALLUMINIO ALF4AP

ALF4AP ALUMINIUM FILTER  
FILTRO DE ALUMINIO ALF4AP

p. 20

## FILTRI STATICI

p. 22

STATIC FILTERS  
FILTROS ESTÁTICOS

### FILTRO YLS MEDIA PORTATA

FILTRO YMS BASSA PORTATA  
MEDIUM CAPACITY LINE YLS FILTER  
LOW CAPACITY LINE YMS FILTER  
FILTRO YLS MEDIO CAUDAL  
FILTRO A YMS BAJO CAUDAL

p. 22

### FILTRO IN LINEA ALSF4

ALSF4 LINE FILTER  
FILTRO DE LINEA ALSF4

p. 28

### FILTRO IN LINEA ALSF1

ALSF1 LINE FILTER  
FILTRO DE LINEA ALSF1

p. 24

### FILTRO IN LINEA IN PLASTICA SERIE P-SF3/4/5

### FILTRO IN LINEA IN PLASTICA SERIE P-SF6/7

P-SF3/4/5 PLASTIC LINE FILTER  
P-SF6/7 PLASTIC LINE FILTER  
FILTRO DE LINEA EN PLASTICO SERIE P-SF3/4/5  
FILTRO DE LINEA EN PLASTICO SERIE P-SF6/7

p. 30

### FILTRO IN LINEA ASF3

### FILTRO IN LINEA ALSF3

ASF3 LINE FILTER  
ALSF3 LINE FILTER  
FILTRO DE LINEA ASF3  
FILTRO DE LINEA ALSF3

p. 26

## SCHEDA INFORMATIVA

p. 32

REQUIRED INFORMATION FORM  
FICHA DATOS

## Vantaggi

- Continuità d'esercizio: evita i fermo impianto dovuti alla pulizia dei comuni filtri statici in linea o alla pulizia in controlavaggio del filtro stesso.
- Costi di esercizio contenuti: bassa potenza elettrica impiegata, minore manutenzione su particolari a valle del filtro quali ugelli spruzzatori, guarnizioni ecc.
- Scarico delle impurità.
- Manutenzione facilitata: pochi componenti soggetti ad usura, semplicità nelle operazioni di smontaggio, possibilità di programmare interventi di manutenzione in collaborazione con la nostra Società.
- Dimensioni contenute: ingombri ridotti per applicazione su qualsiasi impianto.
- Servizio tecnico: studio di soluzioni personalizzate ed assistenza.

## Advantages

- *Continuous Operation: no plant downtimes, which are usually necessary to clean ordinary static filters or backwash the filter itself.*
- *Low running costs, low electricity consumption, less maintenance costs for parts protected by the filter such as spray nozzles, seals etc.*
- *Elimination of impurities.*
- *Easier maintenance: few components subject to wear, simple disassembly procedure, possibility of scheduling maintenance in collaboration with our company.*
- *Compact size: small size to enable installation on any plant.*
- *Technical assistance: study of customized solutions and servicing.*

## Vantajas

- *Continuidad de funcionamiento: elimina las paradas en las instalaciones en las cuales se encuentran montados, debido a la limpieza de los comunes filtros estáticos de línea o a la limpieza en contra lavado del mismo filtro.*
- *Costos de funcionamiento moderados: baja potencia eléctrica empleada, menor mantenimiento en las piezas internas del filtro como boquillas pulverizadoras, juntas, etc.*
- *Vaciado de las impurezas.*
- *Mantenimiento facilitado: pocos componentes sujetos a desgaste, simplicidad en las operaciones de desmontaje, posibilidad de programar intervenciones de mantenimiento en colaboración con nuestra Sociedad.*
- *Dimensiones contenidas: dimensiones máximas reducidas para aplicaciones en cualquier instalación.*
- *Servicio técnico: estudio de soluciones personalizadas y asistencia.*

## Applicazioni

### CARTIERE

Filtrazione di acque da flottatore, filtrazione patine, filtrazione acque scarico verso l'esterno, filtrazione acque da pozzo, fiume.

### INDUSTRIA METALLURGICA

Filtrazione acque primarie, filtrazione acque per raffreddamenti nei toroidi in colata continua, filtrazione su riciclo acque taglio in laminatoi, filtrazione riciclo acque raffreddamenti estrusione alluminio.

### MACCHINE UTENSILI

Filtrazione delle emulsioni lubro-refrigeranti, che in tal modo possono essere riciclate più a lungo.

### PRODUZIONE DI ENERGIA

Trattamento dell'acqua di ricircolo per protezione degli scambiatori di calore da intasamento ed usura.

### IMPIANTI MINERARI

Filtrazione delle acque utilizzate da pompe e tagliatrici a disco, per un utilizzo più sicuro.

### INNEVAMENTO ARTIFICIALE

Filtrazione acque da fiume e lago, filtrazione acque in stazioni di pompaggio, filtrazione finale acqua direttamente su cannoni da neve.

### ALIMENTARE

Filtrazione liquidi primari e di processo, filtrazione acque di lavaggio.

### TESSILE

Filtrazioni acque impiantistica aerotessile, filtrazione acque di riciclo, filtrazione liquidi di processo.

### DEPURAZIONE ACQUE

Prefiltrazione prima degli impianti di trattamento delle acque reflue.

### CHIMICO

Filtrazione acque primarie e di processo.

### APPLICAZIONE GENERALE

I sistemi di filtrazione Eurospray vengono utilizzati per separare le particelle solide in sospensione nei liquidi mediante l'utilizzo di elementi filtranti detti cartucce. La gamma prevede sistemi di filtrazione con filtri AUTOPULENTI e STATICI IN LINEA. Per maggiori delucidazioni ed informazioni sulle applicazioni generiche o sulla Vostra specifica, Vi preghiamo contattare i nostri uffici tecnico e commerciale.

## Applications

### PAPER MILLS

*Filtering of water from flotation units, filtering of coatings, filtering of inlet and discharge coaters, filtering of water from well, rivers.*

### METALLURGICAL INDUSTRY

*Filtering of primary water, filtering of cooling water for continuous casting processes, filtering of recycling water for cutting in rolling mills, filtering of recycling cooling water on aluminium extrusion lines.*

### MACHINE TOOLS

*Filtering of lubricating-cooling emulsions, which may consequently be recycled.*

### PRODUCTION OF ENERGY

*Treatment of recycling water to protect heat exchangers against clogging and wear.*

### MINING PLANTS

*Filtering of water used by pumps and disk cutters, for safer use.*

### ARTIFICIAL SNOW PRODUCTION

*Filtering of water from rivers and lakes, filtering of water at pumping stations, final filtering of water directly on the snow makers and guns.*

### FOOD INDUSTRY

*Filtering of primary and process water, filtering of washing water.*

### TEXTILE INDUSTRY

*Filtering of aero textile plant water, filtering of recycling water, filtering of process liquids.*

### WATER PURIFICATION

*Preliminary filtering upstream from wastewater purification plants.*

### CHEMICAL INDUSTRY

*Filtering of primary and process water.*

### MAIN APPLICATIONS

*Eurospray offers filtering systems to separate the solid particles suspended in liquids by filtering elements called cartridges. The range includes filtering systems with SELF-CLEANING and STATIC LINE filters. For further information on generic applications and your own specific application, please contact our technical and marketing departments.*

## Aplicaciones

### INDUSTRIAS PAPELERAS

*Filtración de aguas desde flotador, filtración patinas, filtración aguas de descarga hacia el exterior, filtración aguas desde pozo, río.*

### INDUSTRIA METALÚRGICA

*Filtración aguas primarias, filtración aguas para enfriamientos en los muelles toroidales en colada continua, filtración en el reciclado aguas de corte en laminadores, filtración reciclado aguas enfriamiento extrusión aluminio.*

### MÁQUINAS-HERRAMIENTAS

*Filtración de las emulsiones lubro-refrigerantes, que de ese modo pueden recircular durante más tiempo.*

### PRODUCCIÓN DE ENERGÍA

*Tratamiento del agua de recirculación para protecciones de los intercambiadores de calor de la obstrucción y el desgaste.*

### MINERÍAS

*Filtración de las aguas utilizadas por bombas y cortadoras de disco, para un uso más seguro.*

### PRODUCCIÓN DE NIEVE ARTIFICIAL

*Filtración aguas de río y lago, filtración aguas en estaciones de bombeo, filtración final agua directamente en los cañones de nieve.*

### INDUSTRIA ALIMENTICIA

*Filtración líquidos primarios y de proceso, filtración aguas de lavado.*

### INDUSTRIA TEXTIL

*Filtración aguas plantas de acondicionamiento aerotextil, filtración aguas de reciclado, filtración líquidos de proceso.*

### DEPURACIÓN AGUAS

*Filtración previa de las plantas de tratamiento de las aguas residuales.*

### INDUSTRIAS QUÍMICAS

*Filtración aguas primarias y de proceso.*

### APLICACIONES PRINCIPALES

*Los sistemas de filtración EUROSPRAY se utilizan para separar las partículas sólidas en suspensión en los líquidos mediante el uso de elementos filtrantes llamados cartuchos. La gama prevé sistemas de filtración con filtros AUTOLIMPIANTES y ESTÁTICOS EN LÍNEA. Para mayores aclaraciones y informaciones sobre aplicaciones genéricas o sobre un argumento específico, les rogamos se pongan en contacto con nuestras oficinas técnicas y comerciales.*

## Principio di funzionamento

Il liquido da filtrare attraversa una cartuccia filtrante depositando le sospensioni solide sulla superficie interna della cartuccia stessa, e fuoriesce con il grado di filtrazione desiderato.

A causa del progressivo deposito sulla parete interna della cartuccia dei solidi sospesi, si crea una differenza di pressione tra ingresso e uscita del filtro. Questo valore viene rilevato da un manometro differenziale il quale, raggiunto il limite impostato, provvederà a trasmettere il segnale al quadro di controllo.

A questo punto viene avviato il ciclo di pulizia automatico della cartuccia filtrante.

La particolare conformazione delle cartucce filtranti agevola il passaggio delle sole particelle di dimensioni inferiori al grado di filtrazione prescelto e la conseguente facilità di rimozione di quelle trattenute.

Il motoriduttore, azionato dalla centralina, mette in rotazione un albero sul quale sono montate lame raschianti che provvedono a staccare le impurità accumulate.

Le stesse sono disponibili in acciaio inox + PTFE o un sistema speciale brevettato, adatto all'asportazione di fibre difficilmente eliminabili dalla superficie filtrante.

Tutto lo sporco viene poi eliminato tramite l'apertura di una valvola di scarico in acciaio inox, a passaggio totale pneumocomandata, posta sul fondo del filtro.

Il pannello di controllo che governa tutte le operazioni di pulizia del filtro, ha possibilità di adattarsi anche a voltaggi particolari.

È predisposto per il ciclo completamente automatico operando secondo le impostazioni effettuate dall'utente (tempi di lavoro, tempi di pausa, livello di pressione al manometro differenziale).

Nel caso si desideri interfacciare il filtro con i controlli generali dell'impianto, è possibile remotizzare i comandi secondo le esigenze del cliente.

Appositi attacchi posti sul filtro consentono di effettuare controlavaggio manuale della cartuccia a fine lavoro.

## Operating principle

*The liquid to be filtrated passes through a filter cartridge, deposits the suspended solid particles on the inner surface of the cartridge, and comes out with the desired filtration degree. The progressive deposit of suspended solids on the inner wall of the cartridge creates a difference in pressure between the inlet and outlet of the filter.*

*The differential pressure gauge detects the pressure drop, which, once the limit set has reached, it will send the relevant signal to the control panel. At this point, the automatic filter cartridge-cleaning cycle starts. The special design of the filter cartridges facilitates the passage of the particles smaller than the chosen filtration degree only and the removal of those withheld inside it.*

*The gear reduction unit, driven by the control unit, sets in motion the rotation of the scrapers blades or SS brushes carrier shaft, to remove the impurities that have stuck on filtering element.*

*The blades are available in PTFE + Stainless Steel and the brushes are available in Stainless Steel, or a special patented system, suitable for the elimination of fibres that are difficult to remove from the surface of the cartridge. All the dirt is then evacuated through a free-passage pneumatic or electric stainless steel drain valve fitted on the bottom of the filter.*

*The control panel that controls all the filter cleaning operations can also be adapted to special voltage values.*

*We set filter by default for the fully automatic cycle based on the settings made by the user ( working times, pause times, pressure level on the differential pressure gauge ).*

*In the case of the customer wishing to interface the filter controls with the main plant control panel, this can be achieved via remote access to meet the customers specification.*

*Special couplings on the filter body enable the cartridge to be backwashed manually at the end of the job.*

## Principio de funcionamiento

*El líquido a filtrar atraviesa un cartucho filtrante depositando las suspensiones sólidas en la superficie interna del mismo cartucho y vuelve a salir con el grado de filtración deseado.*

*A causa del progresivo depósito en la pared interna del cartucho de los sólidos en suspensión, se crea una diferencia de presión entre la entrada y la salida del filtro. Este valor es detectado por un manómetro diferencial el cual, una vez alcanzado el límite establecido, se encargará de transmitir la señal al cuadro de control. En dicho momento se pone en marcha el ciclo de limpieza automático del cartucho filtrante.*

*La especial conformación de los cartuchos filtrantes agiliza el paso sólo de las partículas de dimensiones inferiores al grado de filtración elegido y la consecuente facilidad de remoción de aquellas retenidas.*

*El motorreductor, accionado desde la centralita, pone en rotación un árbol en el cual están montadas unas cuchillas que se encargan de despegar las impurezas acumuladas. Las mismas están disponibles, en acero inox + PTFE o en un sistema especial patentado, apto para la remoción de fibras que difícilmente pueden eliminarse de la superficie filtrante.*

*Toda la suciedad es eliminada a continuación mediante la apertura de una válvula de descarga en acero inox, para el paso total con mando neumático, ubicada en el fondo del filtro.*

*El panel de control, que gobierna todas las operaciones de limpieza del filtro, tiene la posibilidad de adaptarse incluso si posee voltajes especiales.*

*Está predisuesto para el ciclo completamente automático operando según las regulaciones efectuadas por el usuario (tiempos de trabajo, tiempos de pausa, nivel de presión en el manómetro diferencial).*

*En el caso se desee interconectar el filtro con los controles generales de la instalación, es posible convertir los mandos en remotos según las exigencias del cliente.*

*Especiales conexiones colocadas en el filtro permiten efectuar un contra lavado manual del cartucho al final del trabajo.*

**Schema di funzionamento**  
**Operating diagram**  
**Esquema de funcionamiento**

Centralina di comando  
Control unit  
Centralita de control



Motoriduttore  
Gear reduction unit  
Moterreductor

Manometro differenziale  
Differential pressure gauge  
Manometro diferencial

Liquido in entrata  
Liquid at inlet  
Liquido en entrada

Liquido in uscita  
Liquid at outlet  
Liquido en salida

Liquido di controlavaggio  
Backwashing fluid  
Fluido de contra lavado

Lame raschiarti  
Scraper blades  
Cuchillas raspadoras

Cartuccia filtrante con barre a "V"  
Filter cartridge with V-shaped bars  
Cartucho filtrante con barras a "V"

Fluido di controlavaggio  
Backwashing fluid  
Fluido de contra lavado

Valvola di scarico  
Discharge valves  
Válvula de descarga

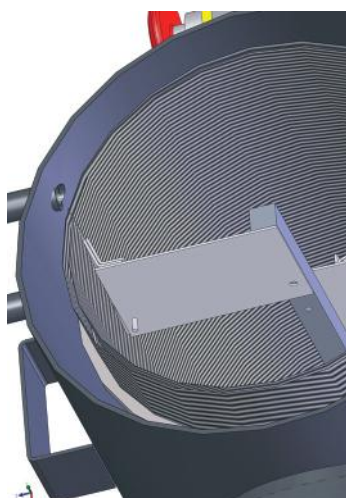

Lama raschiante in acciaio INOX brevettata  
Scraper blade made of PTFE + stainless steel  
Cuchilla raspadora an PTFE + acero INOX PATENTADO

Sistema pulizia a fili inox  
Clearing system btash made in ss  
Sistema de limpieza con cepillos inox:

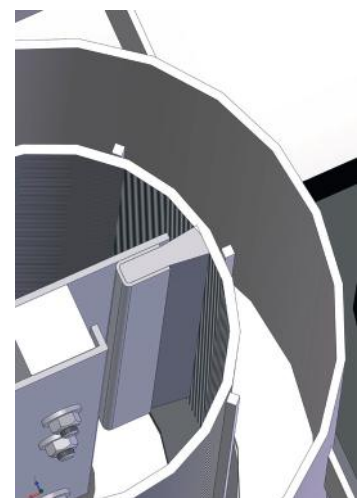

## FILTRO HHF ALTISSIME PORTATE

### HHF HIGHEST FLOW RATE FILTER

### FILTRO HHF CAUDAL MÁS ALTO

#### Descrizione generale

Il modello autopulente HHF ha la possibilità di filtrare grandissimi volumi di liquidi, in accordo alle quantità e tipo di contaminante da filtrare, senza dover effettuare fermi d'impianto.

#### General description

The HHF self-cleaning filter is capable of filtering very large volumes of liquids, according to the amount and types of contaminants to be filtrated, with no plant downtimes.

#### Descripción general

El filtro autolimpiante HHF tiene la posibilidad de filtrar muy grandes volúmenes de líquidos, de acuerdo con las cantidades y el tipo de contaminante que debe filtrarse, sin tener que efectuar paradas en la instalación.

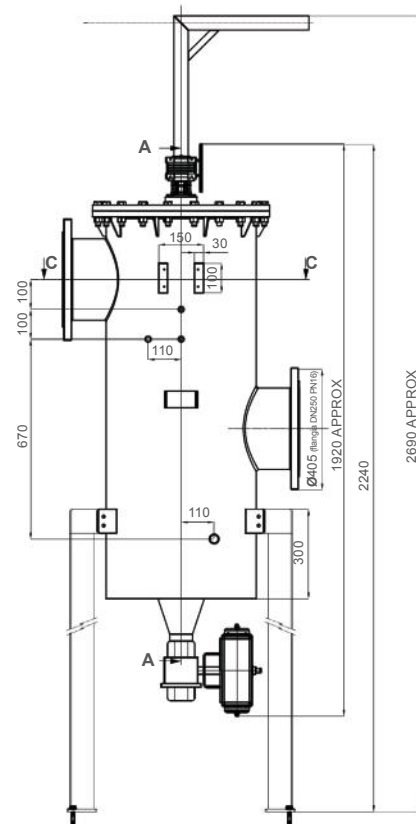

PESO 280 Kg  
 WEIGHT  
 PESO

#### Caratteristiche tecniche

#### Technical specifications

#### Características técnicas

|  |  |
|--|--|
| PRESSIONE D'ESERCIZIO<br>OPERATING PRESSURE<br>PRESIÓN DE FUNCIONAMIENTO                                 | 7 barg   |
| GRADI DI FILTRAZIONE<br>FILTRATION DEGREES<br>GRADOS DE FILTRACIÓN                                       | Da 50 µ in su / From 50 µ onwards / A partir de 50 µ |
| PRESSIONE DI PROGETTO<br>DESIGN PRESSURE<br>PRESIÓN DE PROYECTO  | 10 barg  |
| TEMPERATURA MASSIMA D'ESERCIZIO<br>MAXIMUM OPERATING TEMPERATURE<br>TEMPERATURA MÁXIMA DE FUNCIONAMIENTO | 70°C   |
| FLANGE ENTRATA/USCITA<br>INLET / OUTLET FLANGES<br>BRIDAS ENTRADA/SALIDA                                 | DN250  |
| SCARICO<br>DISCHARGE<br>DESCARGA   | Ø2" 1/2  |
| MOTORIDUTTORE AD INGRANAGGI<br>COUPLING FOR BACK WASHING GEAR MOTOR<br>MOTORREDUCTOR CON ENGRANAJES      |  |
| VALVOLA DI SCARICO AUTOMATICA<br>AUTOMATIC DRAIN VALVE<br>VÁLVULA DE DESCARGA AUTOMÁTICA                 | 24 V a.c.  |
| INDICATORE DI PRESSIONE DIFFERENZIALE<br>DIFFERENTIAL PRESSURE GAUGE<br>INDICADOR DE PRESIÓN DIFERENCIAL | 0 ÷ 0,7 barg   |
| CENTRALINA DI COMANDO<br>CONTROL UNIT<br>CENTRALITA DE MANDO   | 230/400 V - 3 FASI / PHASE / FASES - 50 HZ           |



FLOW MAX WITH 1 GR/LT  
OF SUSPENDED SOLID PUNCHED HOLE

Data test with H<sub>2</sub>O at 20°C

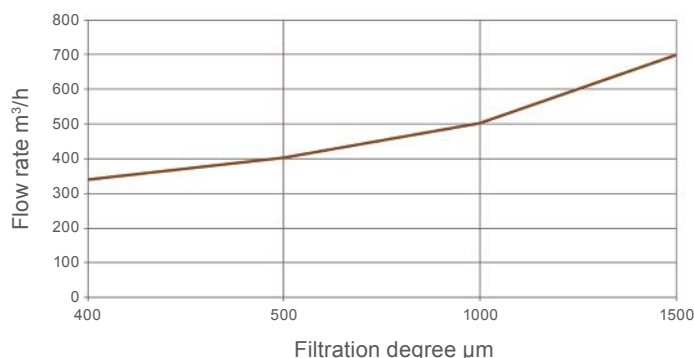

FLOW MAX WITH 1 GR/LT  
OF SUSPENDED SOLID VEE BARS

Data test with H<sub>2</sub>O at 20°C

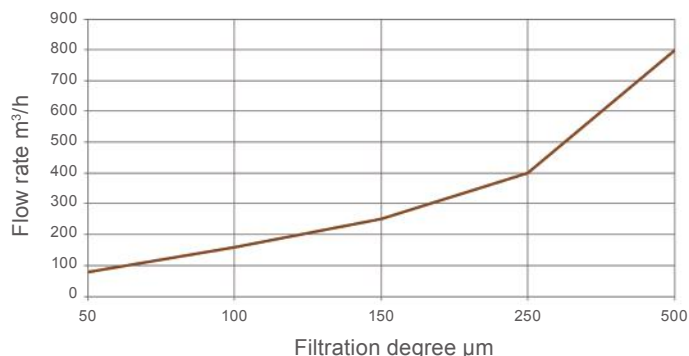

Sono studiate versioni speciali con caratteristiche fuori standard secondo compilazione della scheda raccolta dati a fondo catalogo. Disponibili versioni speciali a pulizia manuale con volantino.

Special versions are studied for out of standard characteristics, kind apply by filling in application form at the end of catalog. Special versions are available for cleaning by hand-wheel drive.

Estan disponibles versiones especiales con características bajo pedido, rellenando la ficha de recogida de datos que encontrarán al final del catálogo. Se fabrican versiones especiales con un sistema de limpieza manual con volante.

## Costruzione

I materiali del corpo del filtro, come tutte le parti che vengono a contatto con il liquido da filtrare, sono in acciaio inox 304L, a richiesta anche in AISI 316, mentre la cartuccia è in AISI 316. Guarnizioni in Viton e EPDM. Altri materiali a richiesta.

## Materials

The filter body as well as all the parts that are exposed to the liquid to be filtered are AISI 304L stainless steel made or AISI 316 steel on request. The seals are Viton and EPDM. Other material on request.

## Construcción

Los materiales del cuerpo del filtro, como todas las partes que están en contacto con el líquido a filtrar, son de acero inox AISI 304L, sobre pedido incluso de AISI 316. Juntas de Viton y EPDM. Otros materiales sobre pedido.

## Cartuccia filtrante

Si possono montare due modelli di cartucce filtranti in base al liquido ed al contaminante da filtrare:

- a barre a "V" disposte radialmente
- a fori punzonati dall'interno della cartuccia

## Filter cartridge

According to the type of liquid and contaminating material different models of filter cartridge can be fitted:

- with radial arranged V-shaped bars
- with punched holes from the inside of the cartridge

## Cartucho filtrante

Se pueden montar dos modelos de cartuchos filtrantes en base al líquido y al contaminante a filtrar:

- con barras en "V" colocadas circunferencialmente
- con agujeros, que funcionan desde el interior del cartucho

## Portate

Valori di portata max in m<sup>3</sup>/h determinate con perdita di carico di 0,2/0,3 barg, con differenti tipi di cartucce.

## Flow rate

Maximum flow rates (m<sup>3</sup>/h) values determined with a pressure drop of 0.2-0.3 barg, with different types of filter cartridges.

## Caudales

Valores de caudal máx. en m<sup>3</sup>/h determinados con pérdida de carga de 0,2/0,3 barg, con diferentes tipos de cartuchos filtrantes.

### FLOW RATE MAX WITH CLEAN WATER

| TYPE OF FILTER    | Surface area of cartridge (dm <sup>2</sup> ) | 1500 µ 11 mesh       |                               | 1000 µ 18 mesh     |                               | 500 µ 35 mesh      |                               | 400 µ 40 mesh       |                               | 250 µ 60 mesh     |                               | 150 µ 100 mesh    |                               | 100 µ 150 mesh   |                               | 50 µ 400 mesh      |                               |
|-------------------|--|----------------------|-------------------------------|--------------------|-------------------------------|--------------------|-------------------------------|---------------------|-------------------------------|-------------------|-------------------------------|-------------------|-------------------------------|------------------|-------------------------------|--------------------|-------------------------------|
|                   |  | free pas-sage        | flow rate (m <sup>3</sup> /h) | free pas-sage      | flow rate (m <sup>3</sup> /h) | free pas-sage      | flow rate (m <sup>3</sup> /h) | free pas-sage       | flow rate (m <sup>3</sup> /h) | free pas-sage     | flow rate (m <sup>3</sup> /h) | free pas-sage     | flow rate (m <sup>3</sup> /h) | free pas-sage    | flow rate (m <sup>3</sup> /h) | free pas-sage      | flow rate (m <sup>3</sup> /h) |
| HHF punched holes | 113  | 32,4 % EMPTY ON FULL | 980                           | 22 % EMPTY ON FULL | 760                           | 10 % EMPTY ON FULL | 620                           | 6,5 % EMPTY ON FULL | 550                           |                   |                               |                   |                               |                  |                               |                    |                               |
| HHF Vee bars      | 113  |                      |                               |                    |                               | 33 % FREE PASSAGE  | 1200                          |                     |                               | 20 % FREE PASSAGE | 600                           | 13 % FREE PASSAGE | 380                           | 9 % FREE PASSAGE | 280                           | 4,7 % FREE PASSAGE | 160                           |

## FILTRO HF ALTA PORTATA

### HF HIGH FLOW RATE FILTER

### FILTRO HF ALTO CAUDAL

#### Descrizione generale

Il filtro autopulente HF ha la possibilità di filtrare grandi volumi di liquidi, in accordo alle quantità e tipo di contaminante da filtrare, senza dover effettuare fermi d'impianto.

#### General description

The HF self-cleaning filter is capable of filtering large volumes of liquids, according on the amount and types of contaminants to be filtrated, with no plant downtimes.

#### Descripción general

El filtro autolimpiante HF tiene la posibilidad de filtrar grandes volúmenes de líquidos, de acuerdo con las cantidades y el tipo de contaminante que debe filtrarse, sin tener que efectuar paradas en la instalación.

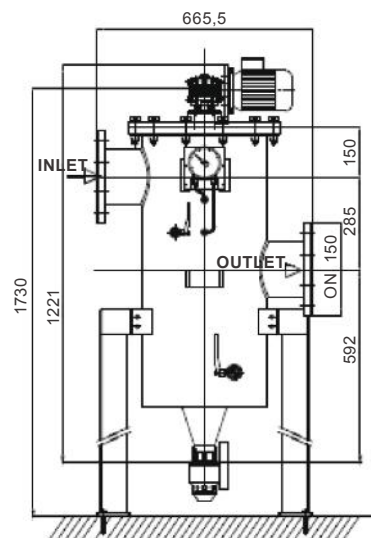

PESO 150 Kg  
 WEIGHT  
 PESO

#### Caratteristiche tecniche

#### Technical specifications

#### Características técnicas

|  |  |
|--|--|
| PRESSIONE D'ESERCIZIO<br>OPERATING PRESSURE<br>PRESIÓN DE FUNCIONAMIENTO                                 | 7 barg   |
| GRADI DI FILTRAZIONE<br>FILTRATION DEGREES<br>GRADOS DE FILTRACIÓN                                       | Da 50 µ in su / From 50 µ onwards / De 50 µ hacia arriba                 |
| PRESSIONE DI PROGETTO<br>DESIGN PRESSURE<br>PRESIÓN DE PROYECTO  | 10 barg  |
| TEMPERATURA MASSIMA D'ESERCIZIO<br>MAXIMUM OPERATING TEMPERATURE<br>TEMPERATURA MÁXIMA DE FUNCIONAMIENTO | 70°C   |
| FLANGE ENTRATA/USCITA<br>INLET / OUTLET FLANGES<br>BRIDAS ENTRADA/SALIDA                                 | DN150  |
| SCARICO<br>DISCHARGE<br>DESCARGA   | Ø2"  |
| MOTORIDUTTORE AD INGRANAGGI<br>COUPLING FOR BACK WASHING GEAR MOTOR<br>MOTORREDUCTOR CON ENGRANAJES      |  |
| VALVOLA DI SCARICO AUTOMATICA<br>AUTOMATIC DRAIN VALVE<br>VÁLVULA DE DESCARGA AUTOMÁTICA                 | 24 V a.c.  |
| INDICATORE DI PRESSIONE DIFFERENZIALE<br>DIFFERENTIAL PRESSURE GAUGE<br>INDICADOR DE PRESIÓN DIFERENCIAL | 0 ÷ 0,7 barg   |
| CENTRALINA DI COMANDO<br>CONTROL UNIT<br>CENTRALITA DE MANDO   | 230/400 V - 3 FASI / PHASE / FASES - 50 HZ                               |
| ATTACCHI PER CONTRALAVAGGI<br>COUPLINGS FOR BACK WASHING<br>CONEXIONES DE LOS CONTRA-LAVADOS             | valvole a sfera manuale / manual ball valves / válvulas de esfera manual |

FLOW MAX WITH 1 GR/LT  
OF SUSPENDED SOLID PUNCHED HOLE

Data test with H<sub>2</sub>O at 20°C

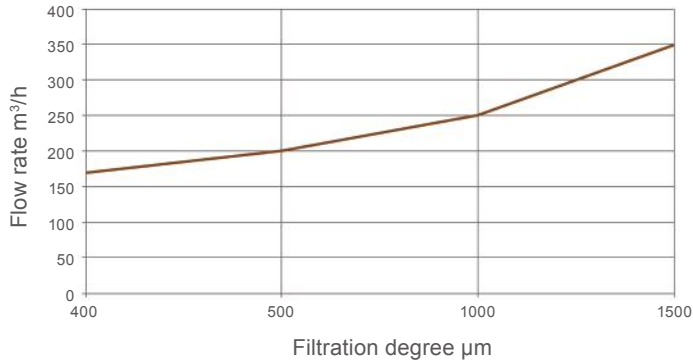

FLOW MAX WITH 1 GR/LT  
OF SUSPENDED SOLID VEE BARS

Data test with H<sub>2</sub>O at 20°C

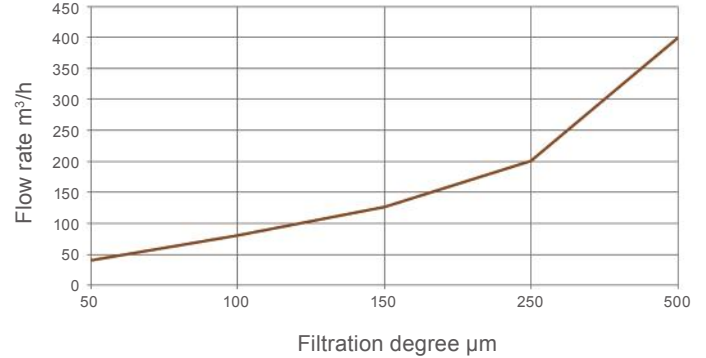

Sono studiate versioni speciali con caratteristiche fuori standard secondo compilazione della scheda raccolta dati a fondo catalogo. Disponibili versioni speciali a pulizia manuale con volantino.

*Special versions are studied for out of standard characteristics, kind apply by filling in application form at the end of catalog. Special versions are available for cleaning by hand-wheel drive.*

*Estan disponibles versiones especiales con características bajo pedido, rellinando la ficha de recogida de datos que encontrarán al final del catálogo. Se fabrican versiones especiales con un sistema de limpieza manual con volante.*

## Costruzione

I materiali del corpo del filtro, come tutte le parti che vengono a contatto con il liquido da filtrare, sono in acciaio inox AISI 304L, a richiesta anche in AISI 316. Guarnizioni in Viton e EPDM.  
Altri materiali a richiesta.

## Materials

*The filter body as well as all the parts that are exposed to the liquid to be filtered are AISI 304L stainless steel made or AISI 316 steel on request. The seals are Viton and EPDM. Other material on request.*

## Construcción

*Los materiales del cuerpo del filtro, como todas las partes que están en contacto con el líquido a filtrar, son de acero inox AISI 304L, sobre pedido incluso de AISI 316. Juntas de Viton y EPDM. Otros materiales sobre pedido.*

## Cartuccia filtrante

Si possono montare due modelli di cartucce filtranti in base al liquido ed al contaminante da filtrare:

- a barre a "V" disposte radialmente
- a fori punzonati dall'interno della cartuccia

## Filter cartridge

*According to the type of liquid and contaminating material different models of filter cartridge can be fitted:*

- with radial arranged V-shaped bars
- with punched holes from the inside of the cartridge

## Cartucho filtrante

*Se pueden montar dos modelos de cartuchos filtrantes en base al líquido y al contaminante a filtrar:*

- con barras en "V" colocadas circunferencialmente
- con agujeros, que funcionan desde el interior del cartucho

## Portate

Valori di portata max in m<sup>3</sup>/h determinate con perdita di carico di 0,2/0,3 barg, con differenti tipi di cartucce filtranti.

## Flow rate

*Maximum flow rates (m<sup>3</sup>/h) values determined with a pressure drop of 0.2-0.3 barg, with different types of filter cartridges.*

## Caudales

*Valores de caudal máx. en m<sup>3</sup>/h determinados con pérdida de carga de 0,2/0,3 barg, con diferentes tipos de cartuchos filtrantes.*

### FLOW RATE MAX WITH CLEAN WATER

| TYPE OF FILTER   | Surface area of cartridge (dm <sup>2</sup> ) | 1500 µ 11 mesh       |                               | 1000 µ 18 mesh     |                               | 500 µ 35 mesh      |                               | 400 µ 40 mesh       |                               | 250 µ 60 mesh     |                               | 150 µ 100 mesh    |                               | 100 µ 150 mesh   |                               | 50 µ 400 mesh      |                               |
|------------------|--|----------------------|-------------------------------|--------------------|-------------------------------|--------------------|-------------------------------|---------------------|-------------------------------|-------------------|-------------------------------|-------------------|-------------------------------|------------------|-------------------------------|--------------------|-------------------------------|
|                  |  | free pas-sage        | flow rate (m <sup>3</sup> /h) | free pas-sage      | flow rate (m <sup>3</sup> /h) | free pas-sage      | flow rate (m <sup>3</sup> /h) | free pas-sage       | flow rate (m <sup>3</sup> /h) | free pas-sage     | flow rate (m <sup>3</sup> /h) | free pas-sage     | flow rate (m <sup>3</sup> /h) | free pas-sage    | flow rate (m <sup>3</sup> /h) | free pas-sage      | flow rate (m <sup>3</sup> /h) |
| HF punched holes | 55   | 32,4 % EMPTY ON FULL | 490                           | 22 % EMPTY ON FULL | 380                           | 10 % EMPTY ON FULL | 310                           | 6,5 % EMPTY ON FULL | 250                           |                   |                               |                   |                               |                  |                               |                    |                               |
| HF Vee bars      | 55   |                      |                               |                    |                               | 33 % FREE PASSAGE  | 600                           |                     |                               | 20 % FREE PASSAGE | 300                           | 13 % FREE PASSAGE | 190                           | 9 % FREE PASSAGE | 140                           | 4,7 % FREE PASSAGE | 80                            |

## FILTRO MF MEDIA PORTATA MF MEDIUM FLOW RATE FILTER FILTRO MF MEDIO CAUDAL

### Descrizione generale

Il modello autopulente MF ha la possibilità di filtrare medie quantità di liquidi, in accordo alle quantità e tipo di contaminante da filtrare, senza dover effettuare fermi d'impianto.

### General description

The MF self-cleaning filter is capable of filtering medium volumes of liquids, according to the amount and types of contaminants to be filtrated, with no plant downtimes.

### Descripción general

El filtro autolimpiante MF tiene la posibilidad de filtrar volúmenes medios de líquidos, de acuerdo con las cantidades y el tipo de contaminante que debe filtrarse, sin tener que efectuar paradas en la instalación.

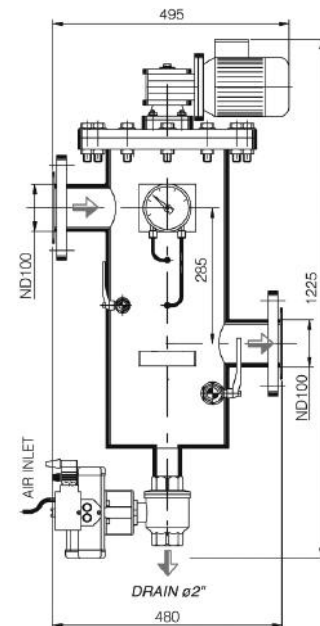

PESO 95 Kg  
WEIGHT  
PESO

### Caratteristiche tecniche

### Technical specifications

### Características técnicas

|  |  |
|--|--|
| PRESSIONE D'ESERCIZIO<br>OPERATING PRESSURE<br>PRESIÓN DE FUNCIONAMIENTO                                 | 10 barg  |
| GRADI DI FILTRAZIONE<br>FILTRATION DEGREES<br>GRADOS DE FILTRACIÓN                                       | Da 50 µ in su / From 50 µ onwards / A partir de 50 µ                     |
| PRESSIONE DI PROGETTO<br>DESIGN PRESSURE<br>PRESIÓN DE PROYECTO  | 15 barg  |
| TEMPERATURA MASSIMA D'ESERCIZIO<br>MAXIMUM OPERATING TEMPERATURE<br>TEMPERATURA MÁXIMA DE FUNCIONAMIENTO | 70°C   |
| FLANGE ENTRATA/USCITA<br>INLET / OUTLET FLANGES<br>BRIDAS ENTRADA/SALIDA                                 | DN100  |
| SCARICO<br>DISCHARGE<br>DESCARGA   | Ø2"  |
| MOTORIDUTTORE AD INGRANAGGI<br>COUPLING FOR BACK WASHING GEAR MOTOR<br>MOTORREDUCTOR CON ENGRANAJES      |  |
| VALVOLA DI SCARICO AUTOMATICA<br>AUTOMATIC DRAIN VALVE<br>VÁLVULA DE DESCARGA AUTOMÁTICA                 | 24 V a.c.  |
| INDICATORE DI PRESSIONE DIFFERENZIALE<br>DIFFERENTIAL PRESSURE GAUGE<br>INDICADOR DE PRESIÓN DIFERENCIAL | 0 ÷ 0,7 barg   |
| CENTRALINA DI COMANDO<br>CONTROL UNIT<br>CENTRALITA DE MANDO   | 230/400 V - 3 FASI / PHASE / FASES - 50 HZ                               |
| ATTACCHI PER CONTROLAVAGGI<br>COUPLINGS FOR BACK WASHING<br>CONEXIONES DE LOS CONTRA-LAVADOS             | valvole a sfera manuale / manual ball valves / válvulas de esfera manual |

**FLOW DIAGRAM WITH 1 GR/LT OF SUSPENDED SOLID PUNCHED HOLE**

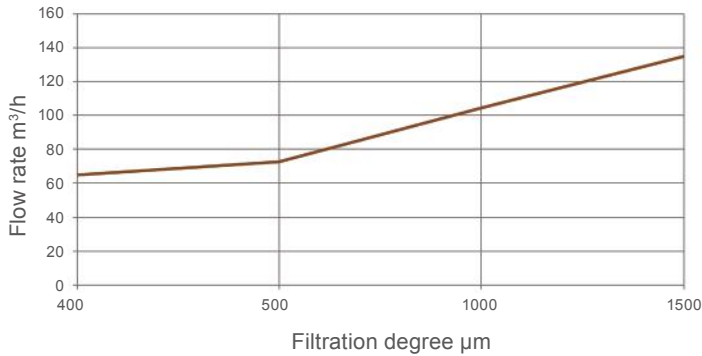
 Data test with H<sub>2</sub>O at 20°C

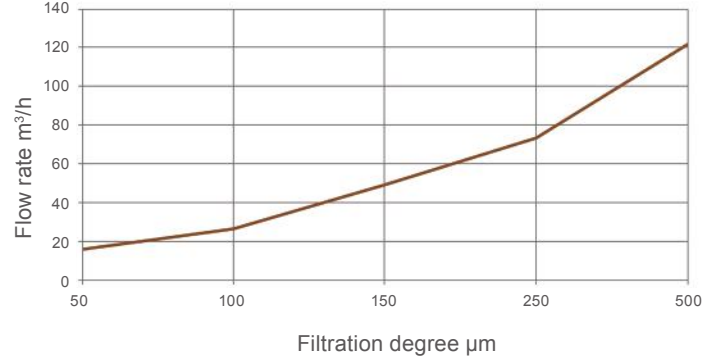
**FLOW DIAGRAM WITH 1 GR/LT OF SUSPENDED SOLID VEE BARS**

 Data test with H<sub>2</sub>O at 20°C

Sono studiate versioni speciali con caratteristiche fuori standard secondo compilazione della scheda raccolta dati a fondo catalogo. Disponibili versioni speciali a pulizia manuale con volantino.

*Special versions are studied for out of standard characteristics, kind apply by filling in application form at the end of catalog. Special versions are available for cleaning by hand-wheel drive*

*Estan disponibles versiones especiales con características bajo pedido, rellinando la ficha de recogida de datos que encontrarán al final del catálogo. Se fabrican versiones especiales con un sistema de limpieza manual con volante.*

### Costruzione

I materiali del corpo del filtro, come tutte le parti che vengono a contatto con il liquido da filtrare, sono in acciaio inox AISI 304L, a richiesta anche in AISI 316 ed acciaio al carbonio. Guarnizioni in Viton e EPDM. Altri materiali a richiesta.

### Materials

*The filter body as well as all the parts that are exposed to the liquid to be filtered are AISI 304L stainless steel made or AISI 316 steel on request. The seals are Viton and EPDM. Other material on request.*

### Construcción

*Los materiales del cuerpo del filtro, como todas las partes que están en contacto con el líquido a filtrar, son de acero inox AISI 304L, sobre pedido incluso de AISI 316 y de acero al carbono. Juntas de Viton y EPDM. Otros materiales sobre pedido.*

### Cartuccia filtrante

Si possono montare due modelli di cartucce filtranti in base al liquido ed al contaminante da filtrare:

- a barre a "V" disposte radialmente
- a fori punzonati dall'interno della cartuccia

### Filter cartridge

*According to the type of liquid and contaminating material different models of filter cartridge can be fitted :*

- with radial arranged V-shaped bars
- with punched holes from the inside of the cartridge

### Cartucho filtrante

*Se pueden montar dos modelos de cartuchos filtrantes en base al líquido y al contaminante a filtrar:*

- con barras en "V" colocadas circunferencialmente
- con agujeros, que funcionan desde el interior del cartucho

### Portate

Valori di portata max in m³/h determinate con perdita di carico di 0,2/0,3 barg, con differenti tipi di cartucce filtranti.

### Flow rate

*Maximum flow rates (m³/h) values determined with a pressure drop of 0.2-0.3 barg, with different types of filter cartridges*

### Caudales

*Valores de caudal máx. en m³/h determinados con pérdida de carga de 0,2/0,3 barg, con diferentes tipos de cartuchos filtrantes.*

#### FLOW RATE MAX WITH CLEAN WATER

| TYPE OF FILTER | Surface area of cartridge (dm²) | 1500 µ 11 mesh   |                  | 1000 µ 18 mesh       |                  | 500 µ 35 mesh      |                  | 400 µ 40 mesh      |                  | 250 µ 60 mesh       |                  | 150 µ 100 mesh    |                  | 100 µ 150 mesh   |                  | 50 µ 400 mesh      |                  |
|----------------|---------------------------------|------------------|------------------|----------------------|------------------|--------------------|------------------|--------------------|------------------|---------------------|------------------|-------------------|------------------|------------------|------------------|--------------------|------------------|
|                |                                 | free pas-sage    | flow rate (m³/h) | free pas-sage        | flow rate (m³/h) | free pas-sage      | flow rate (m³/h) | free pas-sage      | flow rate (m³/h) | free pas-sage       | flow rate (m³/h) | free pas-sage     | flow rate (m³/h) | free pas-sage    | flow rate (m³/h) | free pas-sage      | flow rate (m³/h) |
|                |                                 | MF punched holes | 19               | 32,4 % EMPTY ON FULL | 170              | 22 % EMPTY ON FULL | 130              | 10 % EMPTY ON FULL | 108              | 6,5 % EMPTY ON FULL | 98               |                   |                  |                  |                  |                    |                  |
| MF Vee bars    | 19                              |                  |                  |                      |                  | 33 % FREE PASSAGE  | 208              |                    |                  | 20 % FREE PASSAGE   | 100              | 13 % FREE PASSAGE | 66               | 9 % FREE PASSAGE | 45               | 4,7 % FREE PASSAGE | 23               |

## FILTRO MF-LP MEDIA PORTATA

### MF-LP MEDIUM FLOW RATE FILTER

### FILTRO MF-LP MEDIO CAUDAL

#### Descrizione generale

Il modello autopulente MF-LP ha la possibilità di filtrare medie quantità di liquidi a media e bassa pressione, in accordo alle quantità e tipo di contaminante da filtrare, senza dover effettuare fermi d'impianto.

#### General description

The MF-LP self-cleaning filter is capable of filtering medium volumes of liquids, according to the amount and types of contaminants to be filtrated, with no plant downtimes.

#### Descripción general

El modelo autolimpiante MF-LP tiene la posibilidad de filtrar una cantidad media de agua a presión medio y bajo de acuerdo a la cantidad y tipo de contaminante a filtrar, sin tener que efectuar un paro en la instalación.

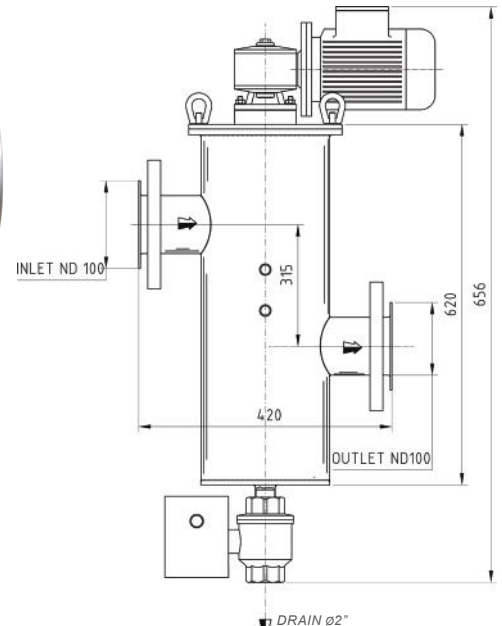

PESO 70 Kg  
 WEIGHT  
 PESO

#### Caratteristiche tecniche

#### Technical specifications

#### Características técnicas

|  |  |
|--|--|
| PRESSIONE D'ESERCIZIO<br>OPERATING PRESSURE<br>PRESIÓN DE FUNCIONAMIENTO                                 | 6 barg max   |
| GRADI DI FILTRAZIONE<br>FILTRATION DEGREES<br>GRADOS DE FILTRACIÓN                                       | Da 50 µ in su / From 50 µ onwards / De 50 µ hacia arriba |
| PRESSIONE DI PROGETTO<br>DESIGN PRESSURE<br>PRESIÓN DE PROYECTO  | 10 barg  |
| TEMPERATURA MASSIMA D'ESERCIZIO<br>MAXIMUM OPERATING TEMPERATURE<br>TEMPERATURA MÁXIMA DE FUNCIONAMIENTO | 70°C   |
| FLANGE ENTRATA/USCITA<br>INLET / OUTLET FLANGES<br>BRIDAS ENTRADA/SALIDA                                 | DN100  |
| SCARICO<br>DISCHARGE<br>DESCARGA   | Ø2"  |
| MOTORIDUTTORE AD INGRANAGGI<br>COUPLING FOR BACK WASHING GEAR MOTOR<br>MOTORREDUCTOR CON ENGRANAJES      |  |
| VALVOLA DI SCARICO AUTOMATICA<br>AUTOMATIC DRAIN VALVE<br>VÁLVULA DE DESCARGA AUTOMÁTICA                 | 24 V a.c.  |
| INDICATORE DI PRESSIONE DIFFERENZIALE<br>DIFFERENTIAL PRESSURE GAUGE<br>INDICADOR DE PRESIÓN DIFERENCIAL | 0 ÷ 0,7 barg   |
| CENTRALINA DI COMANDO<br>CONTROL UNIT<br>CENTRALITA DE MANDO   | 230/400 V - 3 FASI / PHASE / FASES - 50 HZ               |

**FLOW DIAGRAM WITH 1 GR/LT OF SUSPENDED SOLID PUNCHED HOLE**

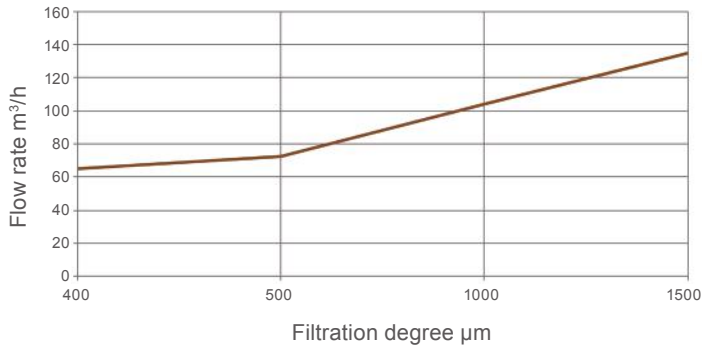
 Data test with H<sub>2</sub>O at 20°C

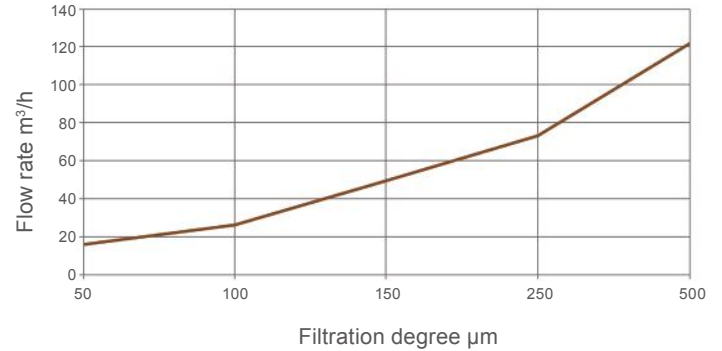
**FLOW DIAGRAM WITH 1 GR/LT OF SUSPENDED SOLID VEE BARS**

 Data test with H<sub>2</sub>O at 20°C

Sono studiate versioni speciali con caratteristiche fuori standard secondo compilazione della scheda raccolta dati a fondo catalogo. Disponibili versioni speciali a pulizia manuale con volantino.

*Special versions are studied for out of standard characteristics, kind apply by filling in application form at the end of catalog. Special versions are available for cleaning by hand-wheel drive*

*Estan disponibles versiones especiales con características bajo pedido, rellinando la ficha de recogida de datos que encontrarán al final del catálogo. Se fabrican versiones especiales con un sistema de limpieza manual con volante.*

### Costruzione

I materiali del corpo del filtro, come tutte le parti che vengono a contatto con il liquido da filtrare, sono in acciaio inox AISI 304L (AISI 316 su richiesta). Guarnizioni in Viton e EPDM. Altri materiali a richiesta.

### Materials

*The filter body as well as all the parts that come into contact with the liquid to be filtered are AISI 304L stainless steel made (AISI 316 steel on request). The seals are Viton and EPDM. Other material on request.*

### Construcción

*El material del cuerpo del filtro así como todas las partes en contacto con el líquido a filtrar son en acero inox AISI 304L. Juntas de Viton y EPDM. Otros materiales sobre pedido.*

### Cartuccia filtrante

Si possono montare tre modelli di cartucce filtranti i base al liquido e al contaminante da filtrare:

- a barre a "V" disposte radialmente
- a fori punzonati dall'interno della cartuccia

### Filter cartridge

*According to the type of liquid and contaminating material different models of filter cartridge can be fitted :*

- with radial arranged V-shaped bars
- with punched holes from the inside of the cartridge

### Cartucho filtrante

*Se pueden montar tres diferentes tipos de cartuchos filtrantes en base al líquido y contaminantes presentes:*

- en barras "V" dispuestas en radio
- en agujeros desde el interior del cartucho

### Portate

Valori di portata max in m<sup>3</sup>/h determinate con perdita di carico di 0.2/0.3 barg, con differenti tipi di cartucce filtranti.

### Flow rate

*Maximum flow rates (m<sup>3</sup>/h) values determined with a pressure drop of 0.2-0.3 barg, with different types of filter cartridges.*

### Caudales

*Valores de caudal máx. en m<sup>3</sup>/h determinados con pérdida de carga de 0,2/0,3 barg, con diferentes tipos de cartuchos filtrantes.*

#### FLOW RATE MAX WITH CLEAN WATER

| TYPE OF FILTER      | Surface area of cartridge (dm <sup>2</sup> ) | 1500 μ 11 mesh       |                               | 1000 μ 18 mesh     |                               | 500 μ 35 mesh      |                               | 400 μ 40 mesh       |                               | 250 μ 60 mesh     |                               | 150 μ 100 mesh    |                               | 100 μ 150 mesh   |                               | 50 μ 400 mesh      |                               |
|---------------------|--|----------------------|-------------------------------|--------------------|-------------------------------|--------------------|-------------------------------|---------------------|-------------------------------|-------------------|-------------------------------|-------------------|-------------------------------|------------------|-------------------------------|--------------------|-------------------------------|
|                     |  | free pas-sage        | flow rate (m <sup>3</sup> /h) | free pas-sage      | flow rate (m <sup>3</sup> /h) | free pas-sage      | flow rate (m <sup>3</sup> /h) | free pas-sage       | flow rate (m <sup>3</sup> /h) | free pas-sage     | flow rate (m <sup>3</sup> /h) | free pas-sage     | flow rate (m <sup>3</sup> /h) | free pas-sage    | flow rate (m <sup>3</sup> /h) | free pas-sage      | flow rate (m <sup>3</sup> /h) |
| MF-LP punched holes | 19   | 32,4 % EMPTY ON FULL | 170                           | 22 % EMPTY ON FULL | 130                           | 10 % EMPTY ON FULL | 108                           | 6,5 % EMPTY ON FULL | 98                            |                   |                               |                   |                               |                  |                               |                    |                               |
| MF-LP Vee bars      | 19   |                      |                               |                    |                               | 33 % FREE PASSAGE  | 208                           |                     |                               | 20 % FREE PASSAGE | 100                           | 13 % FREE PASSAGE | 66                            | 9 % FREE PASSAGE | 45                            | 4,7 % FREE PASSAGE | 23                            |

## FILTRO LF BASSA PORTATA

### LF LOW FLOW RATE FILTER

### FILTRO LF BAJO CAUDAL

#### Descrizione generale

Il filtro autopulente LF è ideale per filtrare piccoli volumi di liquidi, in accordo alle quantità e tipo di contaminante da filtrare, senza dover effettuare fermi d'impianto.

#### General description

The LF self-cleaning filter is capable of filtering small volumes of liquids, according on the amount and types of contaminants to be filtrated, with no plant downtimes.

#### Descripción general

El filtro autolimpiante LF tiene la posibilidad de filtrar pequeños volúmenes de líquidos, de acuerdo con las cantidades y el tipo de contaminante que debe filtrarse, sin tener que efectuar paradas en la instalación.

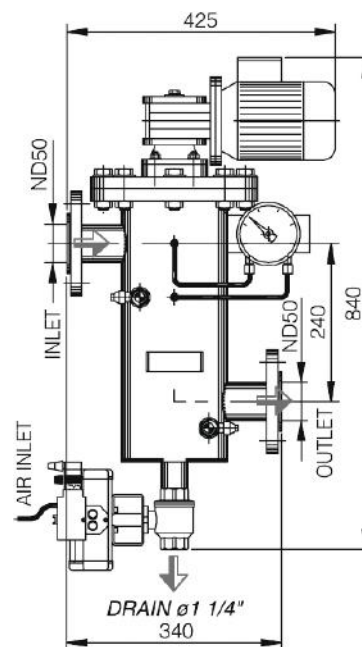
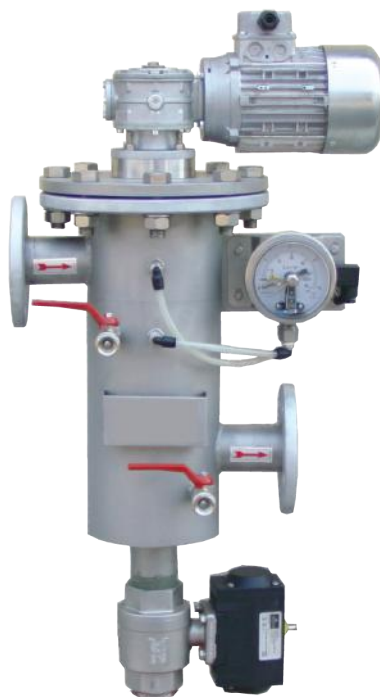

PESO 55 Kg  
 WEIGHT  
 PESO

#### Caratteristiche tecniche

#### Technical specifications

#### Características técnicas

|  |  |  |
|--|--|--|
| PRESSIONE D'ESERCIZIO<br>OPERATING PRESSURE<br>PRESIÓN DE FUNCIONAMIENTO                                 | 10 barg  |  |
| GRADI DI FILTRAZIONE<br>FILTRATION DEGREES<br>GRADOS DE FILTRACIÓN                                       | Da 50 µ in su / From 50 µ onwards / De 50 µ hacia arriba                 |  |
| PRESSIONE DI PROGETTO<br>DESIGN PRESSURE<br>PRESIÓN DE PROYECTO  | 15 barg  |  |
| TEMPERATURA MASSIMA D'ESERCIZIO<br>MAXIMUM OPERATING TEMPERATURE<br>TEMPERATURA MÁXIMA DE FUNCIONAMIENTO | 70°C   |  |
| FLANGE ENTRATA/USCITA<br>INLET / OUTLET FLANGES<br>BRIDAS ENTRADA/SALIDA                                 | DN50   |  |
| SCARICO<br>DISCHARGE<br>DESCARGA   | Ø1" 1/4"   |  |
| MOTORIDUTTORE AD INGRANAGGI<br>COUPLING FOR BACK WASHING GEAR MOTOR<br>MOTORREDUCTOR CON ENGRANAJES      |  |  |
| VALVOLA DI SCARICO AUTOMATICA<br>AUTOMATIC DRAIN VALVE<br>VÁLVULA DE DESCARGA AUTOMÁTICA                 | 24 V a.c.  |  |
| INDICATORE DI PRESSIONE DIFFERENZIALE<br>DIFFERENTIAL PRESSURE GAUGE<br>INDICADOR DE PRESIÓN DIFERENCIAL | 0 ÷ 0,7 barg   |  |
| CENTRALINA DI COMANDO<br>CONTROL UNIT<br>CENTRALITA DE MANDO   | 230/400 V - 3 FASI / PHASE / FASES - 50 HZ                               |  |
| ATTACCHI PER CONTROLAVAGGI<br>COUPLINGS FOR BACK WASHING<br>CONEXIONES DE LOS CONTRA-LAVADOS             | valvole a sfera manuale / manual ball valves / válvulas de esfera manual |  |

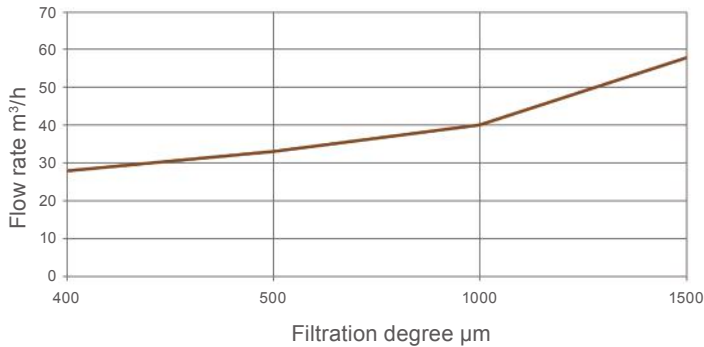

**FLOW DIAGRAM WITH 1 GR/LT OF SUSPENDED SOLID PUNCHED HOLE**

 Data test with H<sub>2</sub>O at 20°C

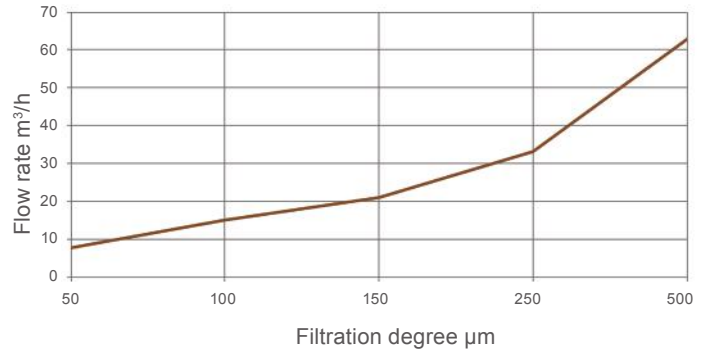
**FLOW DIAGRAM WITH 1 GR/LT OF SUSPENDED SOLID VEE BARS**

 Data test with H<sub>2</sub>O at 20°C

Sono studiate versioni speciali con caratteristiche fuori standard secondo compilazione della scheda raccolta dati a fondo catalogo. Disponibili versioni speciali a pulizia manuale con volantino.

*Special versions are studied for out of standard characteristics, kind apply by filling in application form at the end of catalog. Special versions are available for cleaning by hand-wheel drive*

*Estan disponibles versiones especiales con características bajo pedido, rellinando la ficha de recogida de datos que encontrarán al final del catálogo. Se fabrican versiones especiales con un sistema de limpieza manual con volante.*

### Costruzione

I materiali del corpo del filtro, come tutte le parti che vengono a contatto con il liquido da filtrare, sono in acciaio inox AISI 304L, a richiesta anche in AISI 316 ed acciaio al carbonio. Guarnizioni in Viton e EPDM. Altri materiali a richiesta.

### Materials

*The filter body as well as all the parts that are exposed to the liquid to be filtered are AISI 304L stainless steel made or AISI 316 steel on request. The seals are Viton and EPDM. Other material on request.*

### Construcción

*Los materiales del cuerpo del filtro, como todas las partes que están en contacto con el líquido a filtrar, son de acero inox AISI 304L, sobre pedido incluso de AISI 316 y de acero al carbono. Juntas de Viton y EPDM. Otros materiales sobre pedido.*

### Cartuccia filtrante

Si possono montare due modelli di cartucce filtranti in base al liquido ed al contaminante da filtrare:

- a barre a "V" disposte radialmente
- a fori punzonati dall'interno della cartuccia

### Filter cartridge

*According to the type of liquid and contaminating material different models of filter cartridge can be fitted:*

- with radial arranged V-shaped bars
- with punched holes from the inside of the cartridge

### Cartucho filtrante

*Se pueden montar dos modelos de cartuchos filtrantes en base al líquido y al contaminante a filtrar:*

- con barras en "V" colocadas circunferencialmente
- con agujeros, que funcionan desde el interior del cartucho

### Portate

Valori di portata max in m<sup>3</sup>/h determinate con perdita di carico di 0,2/0,3 barg, con differenti tipi di cartucce filtranti.

### Flow rate

*Maximum flow rates (m<sup>3</sup>/h) values determined with a pressure drop of 0.2-0.3 barg, with different types of filter cartridges.*

### Caudales

*Valores de caudal máx. en m<sup>3</sup>/h determinados con pérdida de carga de 0,2/0,3 barg, con diferentes tipos de cartuchos filtrantes.*

#### FLOW RATE MAX WITH CLEAN WATER

| TYPE OF FILTER   | Surface area of cartridge (dm <sup>2</sup> ) | 1500 µ 11 mesh       |                               | 1000 µ 18 mesh     |                               | 500 µ 35 mesh      |                               | 400 µ 40 mesh       |                               | 250 µ 60 mesh     |                               | 150 µ 100 mesh    |                               | 100 µ 150 mesh   |                               | 50 µ 400 mesh      |                               |
|------------------|--|----------------------|-------------------------------|--------------------|-------------------------------|--------------------|-------------------------------|---------------------|-------------------------------|-------------------|-------------------------------|-------------------|-------------------------------|------------------|-------------------------------|--------------------|-------------------------------|
|                  |  | free pas-sage        | flow rate (m <sup>3</sup> /h) | free pas-sage      | flow rate (m <sup>3</sup> /h) | free pas-sage      | flow rate (m <sup>3</sup> /h) | free pas-sage       | flow rate (m <sup>3</sup> /h) | free pas-sage     | flow rate (m <sup>3</sup> /h) | free pas-sage     | flow rate (m <sup>3</sup> /h) | free pas-sage    | flow rate (m <sup>3</sup> /h) | free pas-sage      | flow rate (m <sup>3</sup> /h) |
| LF punched holes | 9  | 32,4 % EMPTY ON FULL | 78                            | 22 % EMPTY ON FULL | 63                            | 10 % EMPTY ON FULL | 50                            | 6,5 % EMPTY ON FULL | 45                            |                   |                               |                   |                               |                  |                               |                    |                               |
| LF Vee bars      | 9  |                      |                               |                    |                               | 33 % FREE PASSAGE  | 97                            |                     |                               | 20 % FREE PASSAGE | 49                            | 13 % FREE PASSAGE | 30                            | 9 % FREE PASSAGE | 23                            | 4,7 % FREE PASSAGE | 17                            |

## FILTRO LF-LP BASSA PORTATA

### LF-LP LOW FLOW RATE FILTER

### FILTRO LF-LP BAJO CAUDAL

#### Descrizione generale

Il filtro autopulente LF-LP è ideale per filtrare piccoli volumi di liquidi, in accordo alle quantità e tipo di contaminante da filtrare, senza dover effettuare fermi d'impianto.

#### General description

The LF-LP self-cleaning filter is capable of filtering small volumes of liquids, according on the amount and types of contaminants to be filtrated, with no plant downtimes.

#### Descripción general

El filtro autolimpiante LF-LP tiene la posibilidad de filtrar pequeños volúmenes de líquidos, de acuerdo con las cantidades y el tipo de contaminante que debe filtrarse, sin tener que efectuar paradas en la instalación.

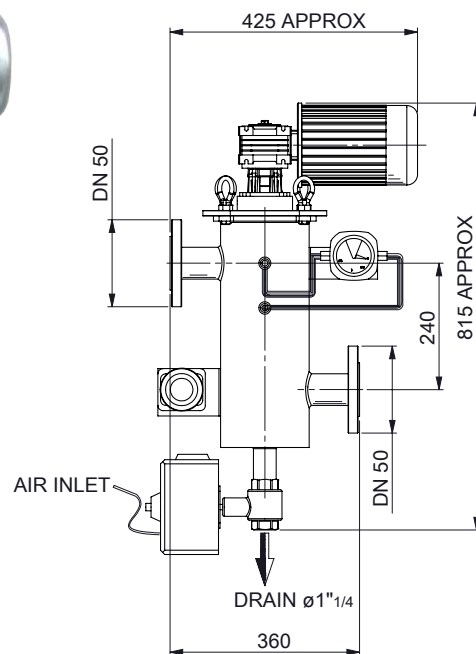

PESO 55 Kg  
 WEIGHT  
 PESO

#### Caratteristiche tecniche

#### Technical specifications

#### Características técnicas

|  |  |
|--|--|
| PRESSIONE D'ESERCIZIO<br>OPERATING PRESSURE<br>PRESIÓN DE FUNCIONAMIENTO                                 | 6 barg   |
| GRADI DI FILTRAZIONE<br>FILTRATION DEGREES<br>GRADOS DE FILTRACIÓN                                       | Da 50 µ in su / From 50 µ onwards / De 50 µ hacia arriba                 |
| PRESSIONE DI PROGETTO<br>DESIGN PRESSURE<br>PRESIÓN DE PROYECTO  | 10 barg  |
| TEMPERATURA MASSIMA D'ESERCIZIO<br>MAXIMUM OPERATING TEMPERATURE<br>TEMPERATURA MÁXIMA DE FUNCIONAMIENTO | 70°C   |
| FLANGE ENTRATA/USCITA<br>INLET / OUTLET FLANGES<br>BRIDAS ENTRADA/SALIDA                                 | DN50   |
| SCARICO<br>DISCHARGE<br>DESCARGA   | Ø1" 1/4"   |
| MOTORIDUTTORE AD INGRANAGGI<br>COUPLING FOR BACK WASHING GEAR MOTOR<br>MOTORREDUCTOR CON ENGRANAJES      |  |
| VALVOLA DI SCARICO AUTOMATICA<br>AUTOMATIC DRAIN VALVE<br>VÁLVULA DE DESCARGA AUTOMÁTICA                 | 24 V a.c.  |
| INDICATORE DI PRESSIONE DIFFERENZIALE<br>DIFFERENTIAL PRESSURE GAUGE<br>INDICADOR DE PRESIÓN DIFERENCIAL | 0 ÷ 0,7 barg   |
| CENTRALINA DI COMANDO<br>CONTROL UNIT<br>CENTRALITA DE MANDO   | 230/400 V - 3 FASI / PHASE / FASES - 50 HZ                               |
| ATTACCHI PER CONTROLAVAGGI<br>COUPLINGS FOR BACK WASHING<br>CONEXIONES DE LOS CONTRA-LAVADOS             | valvole a sfera manuale / manual ball valves / válvulas de esfera manual |

**FLOW DIAGRAM WITH 1 GR/LT OF SUSPENDED SOLID PUNCHED HOLE**

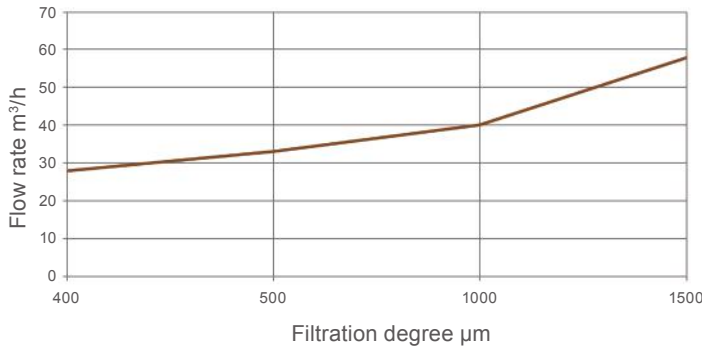
 Data test with H<sub>2</sub>O at 20°C

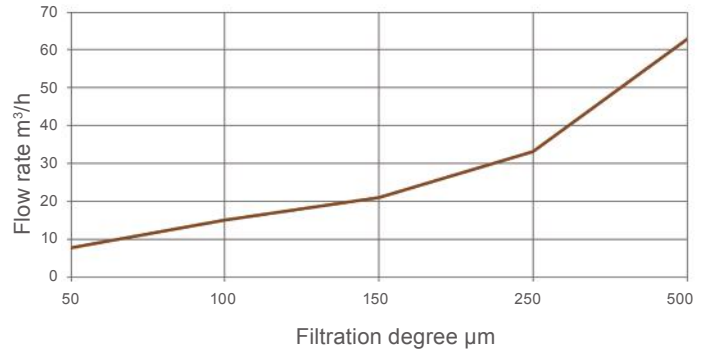
**FLOW DIAGRAM WITH 1 GR/LT OF SUSPENDED SOLID VEE BARS**

 Data test with H<sub>2</sub>O at 20°C

Sono studiate versioni speciali con caratteristiche fuori standard secondo compilazione della scheda raccolta dati a fondo catalogo. Disponibili versioni speciali a pulizia manuale con volantino.

Special versions are studied for out of standard characteristics, kind apply by filling in application form at the end of catalog. Special versions are available for cleaning by hand-wheel drive

Estan disponibles versiones especiales con características bajo pedido, rellinando la ficha de recogida de datos que encontrarán al final del catálogo. Se fabrican versiones especiales con un sistema de limpieza manual con volante.

### Costruzione

I materiali del corpo del filtro, come tutte le parti che vengono a contatto con il liquido da filtrare, sono in acciaio inox AISI 304L, a richiesta anche in AISI 316 ed acciaio al carbonio. Guarnizioni in Viton e EPDM. Altri materiali a richiesta.

### Materials

The filter body as well as all the parts that are exposed to the liquid to be filtered are AISI 304L stainless steel made or AISI 316 steel on request. The seals are Viton and EPDM. Other material on request.

### Construcción

Los materiales del cuerpo del filtro, como todas las partes que están en contacto con el líquido a filtrar, son de acero inox AISI 304L, sobre pedido incluso de AISI 316 y de acero al carbono. Juntas de Viton y EPDM. Otros materiales sobre pedido.

### Cartuccia filtrante

Si possono montare due modelli di cartucce filtranti in base al liquido ed al contaminante da filtrare:

- a barre a "V" disposte radialmente
- a fori punzonati dall'interno della cartuccia

### Filter cartridge

According to the type of liquid and contaminating material different models of filter cartridge can be fitted:

- with radial arranged V-shaped bars
- with punched holes from the inside of the cartridge

### Cartucho filtrante

Se pueden montar dos modelos de cartuchos filtrantes en base al líquido y al contaminante a filtrar:

- con barras en "V" colocadas circunferencialmente
- con agujeros, que funcionan desde el interior del cartucho

### Portate

Valori di portata max in m<sup>3</sup>/h determinate con perdita di carico di 0,2/0,3 barg, con differenti tipi di cartucce filtranti.

### Flow rate

Maximum flow rates (m<sup>3</sup>/h) values determined with a pressure drop of 0.2-0.3 barg, with different types of filter cartridges.

### Caudales

Valores de caudal máx. en m<sup>3</sup>/h determinados con pérdida de carga de 0,2/0,3 barg, con diferentes tipos de cartuchos filtrantes.

#### FLOW RATE MAX WITH CLEAN WATER

| TYPE OF FILTER      | Surface area of cartridge (dm <sup>2</sup> ) | 1500 µ 11 mesh  |                               | 1000 µ 18 mesh  |                               | 500 µ 35 mesh   |                               | 400 µ 40 mesh   |                               | 250 µ 60 mesh  |                               | 150 µ 100 mesh |                               | 100 µ 150 mesh |                               | 50 µ 400 mesh  |                               |
|---------------------|--|-----------------|-------------------------------|-----------------|-------------------------------|-----------------|-------------------------------|-----------------|-------------------------------|----------------|-------------------------------|----------------|-------------------------------|----------------|-------------------------------|----------------|-------------------------------|
|                     |  | free pas-sage   | flow rate (m <sup>3</sup> /h) | free pas-sage   | flow rate (m <sup>3</sup> /h) | free pas-sage   | flow rate (m <sup>3</sup> /h) | free pas-sage   | flow rate (m <sup>3</sup> /h) | free pas-sage  | flow rate (m <sup>3</sup> /h) | free pas-sage  | flow rate (m <sup>3</sup> /h) | free pas-sage  | flow rate (m <sup>3</sup> /h) | free pas-sage  | flow rate (m <sup>3</sup> /h) |
|                     |  | % EMPTY ON FULL |                               | % EMPTY ON FULL |                               | % EMPTY ON FULL |                               | % EMPTY ON FULL |                               | % FREE PASSAGE |                               | % FREE PASSAGE |                               | % FREE PASSAGE |                               | % FREE PASSAGE |                               |
| LF LP punched holes | 9  | 32,4            | 78                            | 22              | 63                            | 10              | 50                            | 6,5             | 45                            |                |                               |                |                               |                |                               |                |                               |
| LF LP Vee bars      | 9  |                 |                               |                 |                               | 33              | 97                            |                 |                               | 20             | 49                            | 13             | 30                            | 9              | 23                            | 4,7            | 17                            |

## FILTRO YLSAP MEDIA PORTATA

### YLSAP MEDIUM FLOW RATE "Y" FILTER

### FILTRO YLSAP MEDIO CAUDAL

#### Descrizione generale

Il filtro autopulente del tipo YLSAP è ideato per le esigenze di filtrazione di particelle in sospensione mediante un sistema completamente automatico a basso costo di installazione, ove però sia necessario utilizzare componenti integralmente in Acciaio Inossidabile.

#### General description

The YLSAP self-cleaning filter is designed to filter suspended particles by means of a fully automatic system with a low installation cost, in which components entirely stainless steel made have to be used.

#### Descripción general

El filtro autolimpiante del tipo YLSAP está ideado para las exigencias de filtración de partículas en suspensión mediante un sistema completamente automático con bajo coste de instalación, pero donde sea necesario utilizar componentes integralmente de Acero Inoxidable.

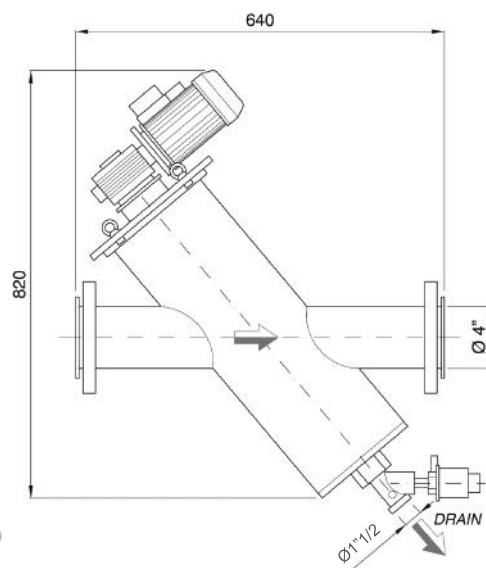

PESO 40 Kg  
 WEIGHT  
 PESO

#### Caratteristiche tecniche

#### Technical specifications

#### Características técnicas

|  |   |
|--|---|
| PRESSIONE D'ESERCIZIO<br>OPERATING PRESSURE<br>PRESIÓN DE FUNCIONAMIENTO                                 | 6 barg  |
| GRADI DI FILTRAZIONE<br>FILTRATION DEGREES<br>GRADOS DE FILTRACIÓN                                       | Da 150 µ in su / From 150 µ onwards / De 150 µ hacia arriba |
| PRESSIONE DI PROGETTO<br>DESIGN PRESSURE<br>PRESIÓN DE PROYECTO  | 10 barg   |
| TEMPERATURA MASSIMA D'ESERCIZIO<br>MAXIMUM OPERATING TEMPERATURE<br>TEMPERATURA MÁXIMA DE FUNCIONAMIENTO | 70°C  |
| FLANGE ENTRATA/USCITA<br>INLET / OUTLET FLANGES<br>BRIDAS ENTRADA/SALIDA                                 | Ø4" UNI PN10  |
| SCARICO<br>DISCHARGE<br>DESCARGA   | Ø 1" 1/2  |
| MOTORIDUTTORE AD INGRANAGGI<br>COUPLING FOR BACK WASHING GEAR MOTOR<br>MOTORREDUCTOR CON ENGRANAJES      |   |
| VALVOLA DI SCARICO AUTOMATICA<br>AUTOMATIC DRAIN VALVE<br>VÁLVULA DE DESCARGA AUTOMÁTICA                 | 24 V a.c.   |
| INDICATORE DI PRESSIONE DIFFERENZIALE<br>DIFFERENTIAL PRESSURE GAUGE<br>INDICADOR DE PRESIÓN DIFERENCIAL | a richiesta / on request / sobre pedido                     |
| CENTRALINA DI COMANDO<br>CONTROL UNIT<br>CENTRALITA DE MANDO   | 230/400 V - 3 FASI / PHASE / FASES - 50 HZ                  |

FLOW DIAGRAM WITH 1 GR/LT OF SUSPENDED SOLID PUNCHED HOLE

FLOW DIAGRAM WITH 1 GR/LT OF SUSPENDED SOLID SCREEN WIRE

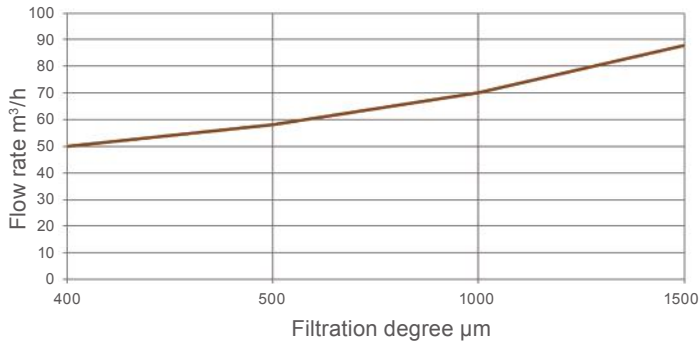
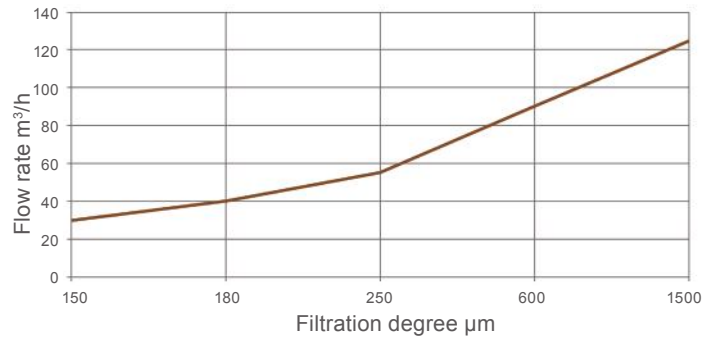
 Data test with H<sub>2</sub>O at 20°C

 Data test with H<sub>2</sub>O at 20°C

### Costruzione

I materiali del corpo del filtro, come tutte le parti che vengono a contatto con il liquido da filtrare, sono in acciaio inox AISI 304L.

### Cartuccia filtrante

La cartuccia standard è in lamiera microstirata, tuttavia si realizzano anche punzonate (secondo necessità).

### Portate

Valori di portata max in m³/h determinati con perdita di carico di 0,2-0,3 bar, con differenti tipi di cartucce filtranti.

### Materials

The filter body as well as all the parts that come into contact with the liquid to be filtered are AISI 304L stainless steel made.

### Filter cartridge

The standard cartridge is made of SS screen wire but punched hole cartridges are also manufactured depending on requirements.

### Flow rate

Maximum flow rates (m³/h) values determined with a pressure drop of 0.2-0.3 bar, with different types of filter cartridges.

### Construcción

Los materiales del cuerpo del filtro, como todas las partes que están en contacto con el líquido a filtrar, son de acero inox AISI 304L.

### Cartucho filtrante

El cartucho estándar es de chapa microstirada, aunque se realizan también punzonados (según necesidad).

### Caudales

Valores de caudal máx. en m³/h determinados con pérdida de carga de 0,2/-0,3 bar, con diferentes tipos de cartuchos filtrantes.

#### FLOW RATE MAX WITH CLEAN WATER

| TYPE OF FILTER      | Surface area of cartridge (dm²) | 1500 µ<br>10 mesh | 1000 µ<br>18 mesh | 600 µ<br>30 mesh | 500 µ<br>35 mesh | 400 µ<br>40 mesh | 250 µ<br>60 mesh | 180 µ<br>80 mesh | 150 µ<br>100 mesh |
|---------------------|---------------------------------|-------------------|-------------------|------------------|------------------|------------------|------------------|------------------|-------------------|
|                     |                                 | flow rate (m³/h)  | flow rate (m³/h)  | flow rate (m³/h) | flow rate (m³/h) | flow rate (m³/h) | flow rate (m³/h) | flow rate (m³/h) | flow rate (m³/h)  |
| YLSAP punched holes | 15                              | 150               | 119               |                  | 99               | 80               |                  |                  |                   |
| YLSAP screen wire   | 15                              | 191               |                   | 157              |                  |                  | 81               | 56               | 49                |

## FILTRO IN ALLUMINIO ALF4AP

### ALF4AP ALUMINIUM FILTER

### FILTRO DE ALUMINIO ALF4AP

#### Descrizione generale

Con questo filtro è possibile filtrare particelle solide in sospensione con un sistema automatico di bassissimo costo d'installazione. Estremamente facile da installare su linee esistenti e in spazi molto limitati, offre i vantaggi tipici di un prodotto collaudato e una notevole semplicità e robustezza costruttiva.

#### General description

*This filter can be used to filter suspended solid particles by an automatic system with very low installation cost. It is extremely easy to install on existing lines and in very limited spaces and offers the typical advances of a tried and tested product and a simple, sturdy design.*

#### Descripción general

*Con este filtro es posible filtrar partículas sólidas en suspensión con un sistema automático de bajísimo coste de instalación. Extremamente fácil de instalar en líneas existentes y en espacios muy limitados, ofrece las ventajas típicas de un producto ensayado y una notable simplicidad y robustez de fabricación.*

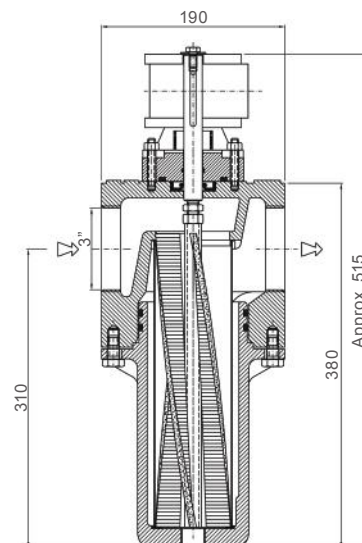

PESO 15 Kg  
 WEIGHT  
 PESO

#### Caratteristiche tecniche

#### Technical specifications

#### Características técnicas

|  |   |
|--|---|
| PRESSIONE D'ESERCIZIO<br>OPERATING PRESSURE<br>PRESIÓN DE FUNCIONAMIENTO                                 | 10 barg   |
| GRADI DI FILTRAZIONE<br>FILTRATION DEGREES<br>GRADOS DE FILTRACIÓN                                       | Da 150 µ in su / From 150 µ onwards / De 150 µ hacia arriba |
| PRESSIONE DI PROGETTO<br>DESIGN PRESSURE<br>PRESIÓN DE PROYECTO  | 15 barg   |
| TEMPERATURA MASSIMA D'ESERCIZIO<br>MAXIMUM OPERATING TEMPERATURE<br>TEMPERATURA MÁXIMA DE FUNCIONAMIENTO | 70°C  |
| FLANGE ENTRATA/USCITA<br>INLET / OUTLET FLANGES<br>BRIDAS ENTRADA/SALIDA                                 | Ø3"   |
| SCARICO<br>DISCHARGE<br>DESCARGA   | Ø1"   |
| MOTORIDUTTORE AD INGRANAGGI<br>COUPLING FOR BACK WASHING GEAR MOTOR<br>MOTORREDUCTOR CON ENGRANAJES      |   |
| VALVOLA DI SCARICO AUTOMATICA<br>AUTOMATIC DRAIN VALVE<br>VÁLVULA DE DESCARGA AUTOMÁTICA                 | 24 V a.c.   |
| INDICATORE DI PRESSIONE DIFFERENZIALE<br>DIFFERENTIAL PRESSURE GAUGE<br>INDICADOR DE PRESIÓN DIFERENCIAL | a richiesta / on request / sobre pedido                     |
| CENTRALINA DI COMANDO<br>CONTROL UNIT<br>CENTRALITA DE MANDO   | 230/400 V - 3 FASI / PHASE / FASES - 50 HZ                  |

**FLOW DIAGRAM WITH 1 GR/LT OF SUSPENDED SOLID PUNCHED HOLE**

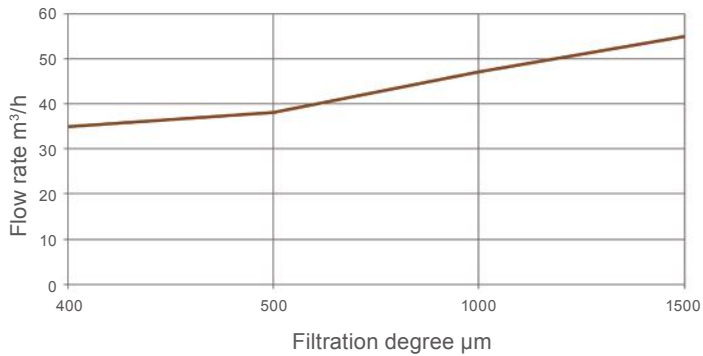
 Data test with H<sub>2</sub>O at 20°C

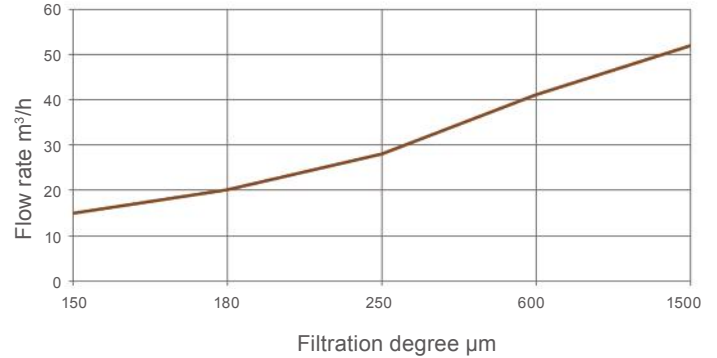
**FLOW DIAGRAM WITH 1 GR/LT OF SUSPENDED SOLID SCREEN WIRE**

 Data test with H<sub>2</sub>O at 20°C

### Costruzione

Esecuzione in lega di Alluminio, cartuccia filtrante in lamiera microstirata inox con diversi gradi di ritenzione.

### Cartuccia filtrante

La cartuccia standard è in lamiera microstirata, tuttavia si realizzano anche punzonate (secondo necessità).

### Portate

Valori di portata max in m<sup>3</sup>/h determinate con perdita di carico di 0,2/0,3 barg, con lamiera microstirata.

### Materials

Aluminium alloy made with SS screen wire filter cartridge with various retention degrees.

### Filter cartridge

The standard cartridge is made of SS screen wire but punched hole cartridges are also manufactured depending on requirements.

### Flow rate

Maximum flow rates (m<sup>3</sup>/h) values determined with a pressure drop of 0.2-0.3 barg, with different types of filter cartridges.

### Construcción

Ejecución en aleación de Aluminio, cartucho filtrante de chapamicro-tensada inox con diferentes grados de retención.

### Cartucho filtrante

El cartucho estándar es de chapa micro-tensada, aunque se realizan también punzonados (según necesidad).

### Caudales

Valores de caudal máx. en m<sup>3</sup>/h determinados con pérdida de carga de 0,2/0,3 barg, con chapa micro-tensada.

**FLOW RATE MAX WITH CLEAN WATER**

| TYPE OF FILTER          | Surface area of cartridge (dm <sup>2</sup> ) | 1500 µ<br>10 mesh             | 1000 µ<br>18 mesh             | 600 µ<br>30 mesh              | 500 µ<br>35 mesh              | 400 µ<br>40 mesh              | 250 µ<br>60 mesh              | 180 µ<br>80 mesh              | 150 µ<br>100 mesh             |
|-------------------------|--|-------------------------------|-------------------------------|-------------------------------|-------------------------------|-------------------------------|-------------------------------|-------------------------------|-------------------------------|
|                         |  | flow rate (m <sup>3</sup> /h) | flow rate (m <sup>3</sup> /h) | flow rate (m <sup>3</sup> /h) | flow rate (m <sup>3</sup> /h) | flow rate (m <sup>3</sup> /h) | flow rate (m <sup>3</sup> /h) | flow rate (m <sup>3</sup> /h) | flow rate (m <sup>3</sup> /h) |
| ALF4AP<br>punched holes | 7  | 60                            | 49                            |                               | 38                            | 35                            |                               |                               |                               |
| ALF4AP<br>screen wire   | 7  | 89                            |                               | 74                            |                               |                               | 42                            | 31                            | 27                            |

**FILTRO YLS MEDIA PORTATA**  
**MEDIUM CAPACITY LINE YLS FILTER**  
**FILTRO YLS MEDIO CAUDAL**

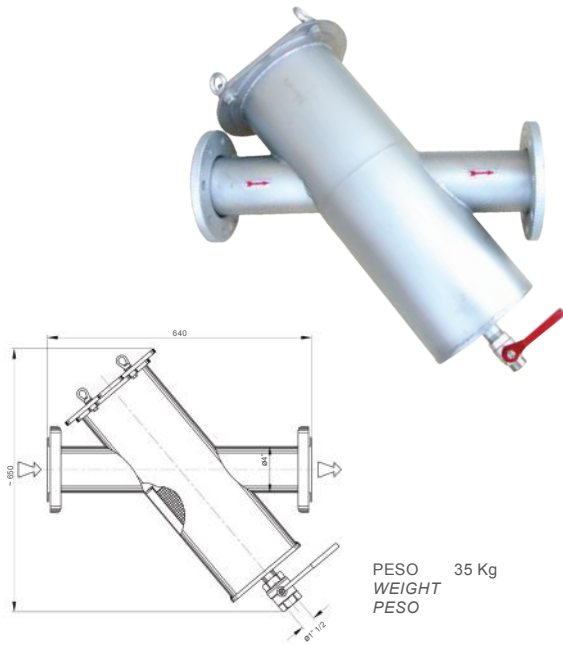

FLOW DIAGRAM WITH 1 GR/LT  
OF SUSPENDED SOLID PUNCHED HOLE

Data test with H<sub>2</sub>O at 20°C

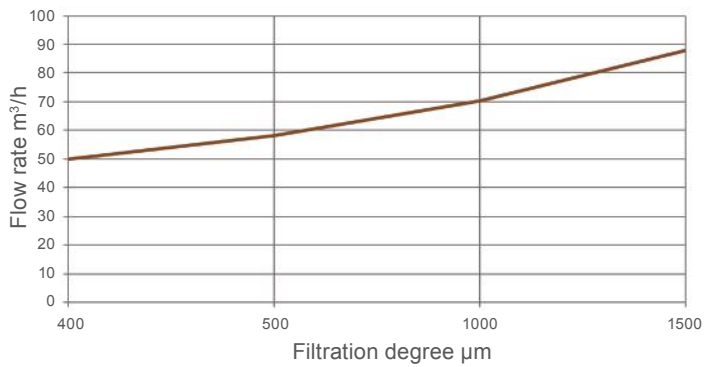

FLOW DIAGRAM WITH 1 GR/LT  
OF SUSPENDED SOLID SCREEN WIRE

Data test with H<sub>2</sub>O at 20°C

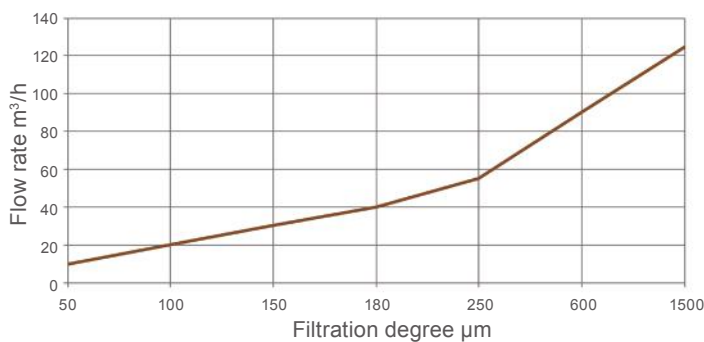

**FILTRO YMS BASSA PORTATA**  
**LOW CAPACITY LINE YMS FILTER**  
**FILTRO YMS BAJO CAUDAL**

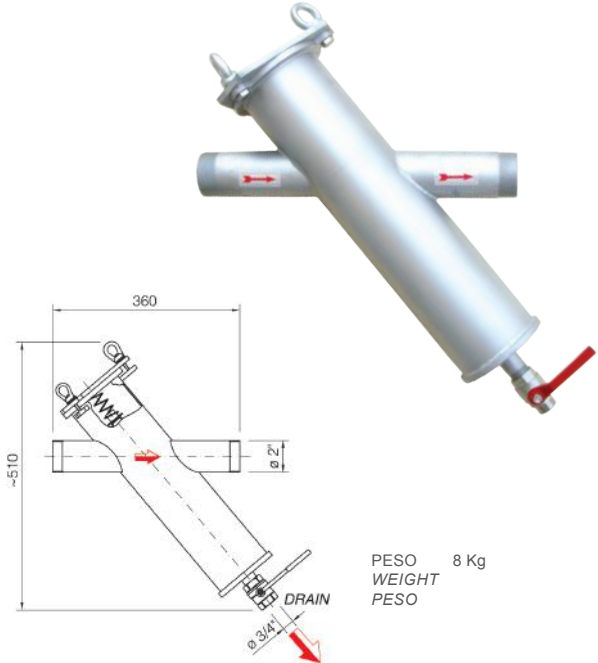

FLOW DIAGRAM WITH 1 GR/LT  
OF SUSPENDED SOLID PUNCHED HOLE

Data test with H<sub>2</sub>O at 20°C

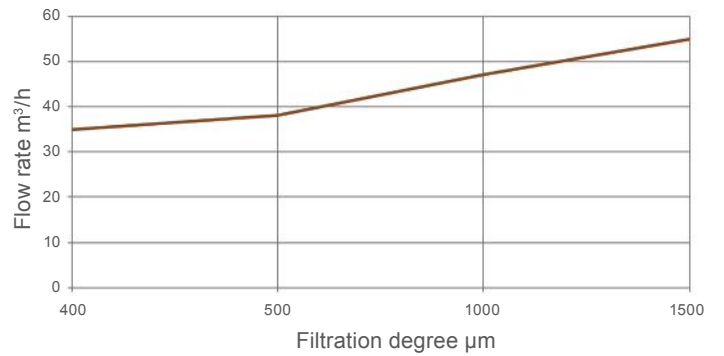

FLOW DIAGRAM WITH 1 GR/LT  
OF SUSPENDED SOLID SCREEN WIRE

Data test with H<sub>2</sub>O at 20°C

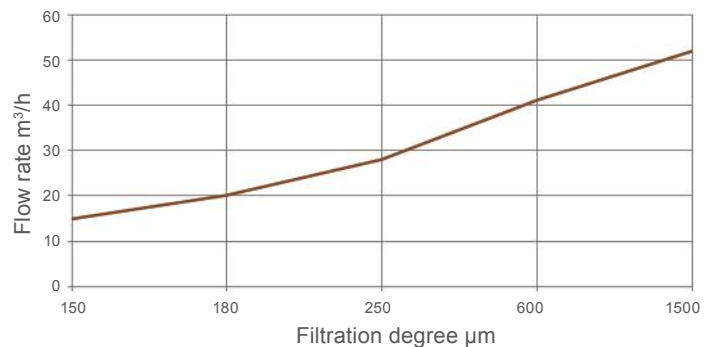



## Descrizione generale

I filtri di linea YLS/YMS sono stati progettati per incontrare le esigenze di filtrazione in linea di solidi sospesi con bassi costi di installazione. I raccordi del modello YLS sono flangiati. I raccordi del modello YMS sono filettati.

## General description

The static line filters YLS/YMS have been designed to meet line filtration requirements for suspended solids with low installation costs. Connections of YLS type are flanged. YMS has threaded connections.

## Descripción general

Los filtros de línea YLS/YMS han sido proyectados para resolver las exigencias de filtración en línea de sólidos en suspensión con bajos costes de instalación. Las uniones del modelo YLS son con brida. Las uniones del modelo YMS están fileteadas.

## Caratteristiche tecniche

## Technical specifications

## Características técnicas

|  |  |
|--|--|
| PRESSIONE D'ESERCIZIO<br>OPERATING PRESSURE<br>PRESIÓN DE FUNCIONAMIENTO                                 | 6 barg   |
| GRADI DI FILTRAZIONE<br>FILTRATION DEGREES<br>GRADOS DE FILTRACIÓN                                       | Da 50 µ in su / From 50 µ ownwards / De 50 µ hacia arriba    |
| PRESSIONE DI PROGETTO<br>DESIGN PRESSURE<br>PRESIÓN DE PROYECTO  | 10 barg  |
| TEMPERATURA MASSIMA D'ESERCIZIO<br>MAXIMUM OPERATING TEMPERATURE<br>TEMPERATURA MÁXIMA DE FUNCIONAMIENTO | 70°C   |
| FLANGE ENTRATA/USCITA<br>INLET / OUTLET FLANGES<br>BRIDAS ENTRADA/SALIDA                                 | YLS - Ø 4" UNI PN10<br>YMS - Ø 2" GAS maschio / male / macho |
| SCARICO<br>DISCHARGE<br>DESCARGA   | YLS - Ø 1" 1/2<br>YMS - Ø 3/4"                               |
| VALVOLA DI SCARICO<br>DRAIN VALVE<br>VÁLVULA DE DESCARGA   | a sfera manuale / manual ball / de esfera manual             |

## Costruzione

L'esecuzione è completamente in acciaio inossidabile AISI 304L.

## Materials

AISI 304L stainless steel made.

## Construcción

La ejecución es totalmente de acero inoxidable AISI 304L.

## Cartuccia filtrante

La cartuccia filtrante è in lamiera microstratata in acciaio inox con diversi gradi di ritenzione.

## Filter cartridge

The filter cartridge is SS screen wire with different retention degrees.

## Cartucho filtrante

El cartucho filtrante es de chapa microstratada de acero inox con diferentes grados de retención.

## Portate

Valori di portata max in m<sup>3</sup>/h con acqua pulita e perdita di carico di 0,2/0,3 barg, con differenti gradi di ritenzione.

## Flow rate

Maximum flow rates (m<sup>3</sup>/h) values determined with a pressure drop of 0.2-0.3 barg, with different types of filter cartridges.

## Caudales

Valores de caudal máx. en m<sup>3</sup>/h con agua limpia y pérdida de carga de 0.2/0.3 barg, con diferentes grados de retención.

### FLOW RATE MAX WITH CLEAN WATER

| TYPE OF FILTER    | Surface area of cartridge (dm <sup>2</sup> ) | 1500 µ                        | 1000 µ                        | 600 µ                         | 500 µ                         | 400 µ                         | 250 µ                         | 180 µ                         | 150 µ                         | 100 µ                         | 50 µ                          |
|-------------------|--|-------------------------------|-------------------------------|-------------------------------|-------------------------------|-------------------------------|-------------------------------|-------------------------------|-------------------------------|-------------------------------|-------------------------------|
|                   |  | 10 mesh                       | 18 mesh                       | 30 mesh                       | 35 mesh                       | 40 mesh                       | 60 mesh                       | 80 mesh                       | 100 mesh                      | 150 mesh                      | 400 mesh                      |
|                   |  | flow rate (m <sup>3</sup> /h) | flow rate (m <sup>3</sup> /h) | flow rate (m <sup>3</sup> /h) | flow rate (m <sup>3</sup> /h) | flow rate (m <sup>3</sup> /h) | flow rate (m <sup>3</sup> /h) | flow rate (m <sup>3</sup> /h) | flow rate (m <sup>3</sup> /h) | flow rate (m <sup>3</sup> /h) | flow rate (m <sup>3</sup> /h) |
| YLS punched holes | 15   | 150                           | 119                           |                               | 99                            | 80                            |                               |                               |                               |                               |                               |
| YLS screen wire   | 15   | 191                           |                               | 157                           |                               |                               | 81                            | 56                            | 49                            | 32                            | 20                            |
| YMS punched holes | 7  | 60                            | 49                            |                               | 38                            | 35                            |                               |                               |                               |                               |                               |
| YMS screen wire   | 7  | 89                            |                               | 74                            |                               |                               | 42                            | 31                            | 27                            | 22                            | 12                            |

**FILTRO IN LINEA ALSF1**  
**ALSF1 LINE FILTER**  
**FILTRO DE LINEA ALSF1**

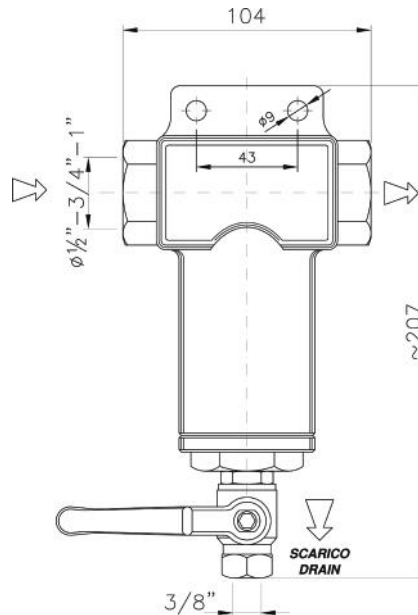

PESO 0,7 Kg  
 WEIGHT  
 PESO

**Descrizione generale**

L'aspetto più caratteristico dei filtri ALSF1 consiste nella grande efficienza di funzionamento dovuto al particolare rapporto fra superficie d'ingresso e superficie filtrante. Inoltre, grazie alla particolare struttura interna, il liquido da filtrare è costretto ad assumere un movimento vorticoso che consente di distribuire le impurità in modo uniforme su tutto l'elemento filtrante portando le particelle solide sul fondo della coppa, garantendo così minori interventi di manutenzione.

**General description**

*The ALSF1 filters most particular characteristic consists of their high performing efficiency due to the ratio between the input area and filtering surface. Moreover thanks to the internal structure, the liquid is forced into a swirling movement which distributes the impurities evenly over the whole cartridge bringing the solid particles onto the base of the bowl. It means less maintenance is required as the result of this.*

**Descripción general**

*El elemento más característico de los filtros ALSF1 consiste en su gran eficiencia de funcionamiento, gracias a la particular relación entre la superficie de entrada y la superficie filtrante. Además, a causa de su particular estructura interna, el líquido a filtrar es obligado a asumir un movimiento de torbellino, que distribuye las impurezas en modo uniforme en todo el elemento filtrante, llevando las partículas sólidas hacia el fondo de la copa y reduciendo así las intervenciones de mantenimiento.*

**Caratteristiche tecniche**

**Technical specifications**

**Características técnicas**

|  |  |
|--|--|
| PRESSIONE D'ESERCIZIO<br>OPERATING PRESSURE<br>PRESIÓN DE FUNCIONAMIENTO                                 | 30 barg  |
| GRADI DI FILTRAZIONE<br>FILTRATION DEGREES<br>GRADOS DE FILTRACIÓN                                       | Da 50 µ in su / From 50 µ onwards / De 50 µ hacia arriba |
| PRESSIONE DI PROGETTO<br>DESIGN PRESSURE<br>PRESIÓN DE PROYECTO  | 45 barg  |
| TEMPERATURA MASSIMA D'ESERCIZIO<br>MAXIMUM OPERATING TEMPERATURE<br>TEMPERATURA MÁXIMA DE FUNCIONAMIENTO | 70°C   |
| FLANGE ENTRATA/USCITA<br>INLET / OUTLET FLANGES<br>BRIDAS ENTRADA/SALIDA                                 | Ø1/2" - 3/4" - 1"  |
| SCARICO<br>DISCHARGE<br>DESCARGA   | Ø3/8"  |
| VALVOLA DI SCARICO<br>DRAIN VALVE<br>VÁLVULA DE DESCARGA   | a sfera manuale / manual ball / de esfera manual         |

**FLOW DIAGRAM WITH 1 GR/LT  
OF SUSPENDED SOLID SCREEN WIRE**

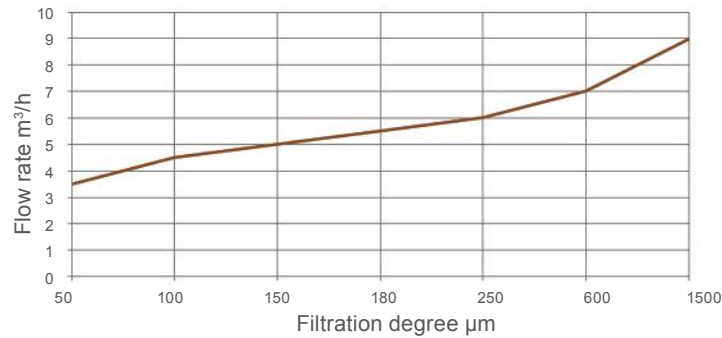
 Data test with H<sub>2</sub>O at 20°C

### Costruzione

I filtri serie ALSF1 sono realizzati in lega di alluminio bonificato di alta qualità.

### Cartuccia filtrante

La cartuccia filtrante è in lamiera microstrirata inox con diversi gradi di ritenzione.

### Portate

Valori di portata max in m<sup>3</sup>/h con acqua pulita e perdita di carico di 0,2/0,3 barg, con differenti gradi di ritenzione.

### Materials

Eurospray ALSF1 series filters are high quality hardened and tempered cast aluminium made.

### Filter cartridge

The filter cartridge screen wire or light-perforated stainless steel with various filtering degrees.

### Flow rate

Maximum flow rates ( m<sup>3</sup>/h) values determined with a pressure drop of 0.2-0.3 barg, with different types of filter cartridges.

### Construcción

Los filtros serie ALSF1 son de aleación de aluminio templado y recocido de elevada calidad.

### Cartucho filtrante

El cartucho filtrante es de chapa micro-tensada inox con diferentes grados de retención.

### Caudales

Valores de caudal máx. en m<sup>3</sup>/h con agua limpia y pérdida de carga de 0.2/0.3 barg, con diferentes grados de retención.

**FLOW RATE MAX WITH CLEAN WATER**

| TYPE OF FILTER    | Surface area of cartridge (dm <sup>2</sup> ) | 1500 µ<br>10 mesh             | 600 µ<br>30 mesh              | 250 µ<br>60 mesh              | 180 µ<br>80 mesh              | 150 µ<br>100 mesh             | 100 µ<br>150 mesh             | 50 µ<br>400 mesh              |
|-------------------|--|-------------------------------|-------------------------------|-------------------------------|-------------------------------|-------------------------------|-------------------------------|-------------------------------|
|                   |  | flow rate (m <sup>3</sup> /h) | flow rate (m <sup>3</sup> /h) | flow rate (m <sup>3</sup> /h) | flow rate (m <sup>3</sup> /h) | flow rate (m <sup>3</sup> /h) | flow rate (m <sup>3</sup> /h) | flow rate (m <sup>3</sup> /h) |
| ALSF1 screen wire | 0,9  | 13                            | 11                            | 9                             | 8,5                           | 8                             | 6                             | 4                             |

**FILTRO IN LINEA ALSF3**  
**ALSF3 LINE FILTER**  
**FILTRO DE LINEA ALSF3**

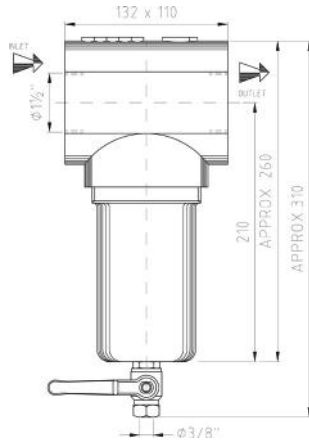

PESO 3,3 Kg  
WEIGHT  
PESO

**FILTRO IN LINEA ASF3**  
**ASF3 LINE FILTER**  
**FILTRO DE LINEA ASF3**

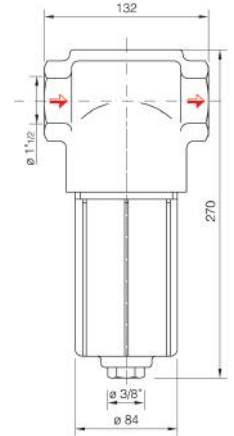
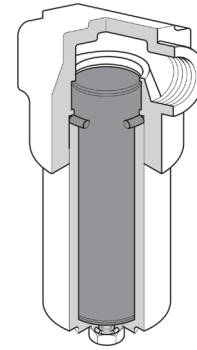

PESO 8 Kg  
WEIGHT  
PESO

FLOW DIAGRAM WITH 1 GR/LT  
OF SUSPENDED SOLID SCREEN WIRE

FLOW DIAGRAM WITH 1 GR/LT  
OF SUSPENDED SOLID SCREEN WIRE

Data test with H<sub>2</sub>O at 20°C

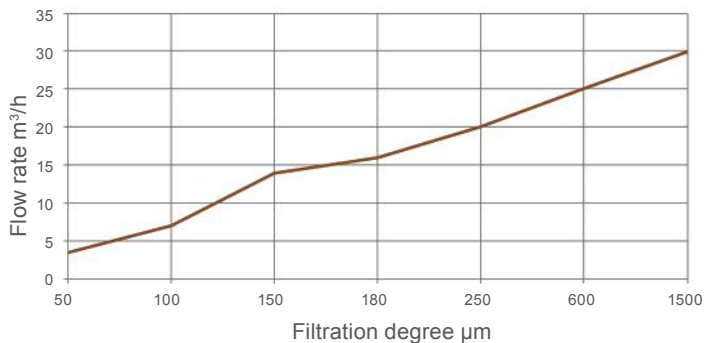

Data test with H<sub>2</sub>O at 20°C

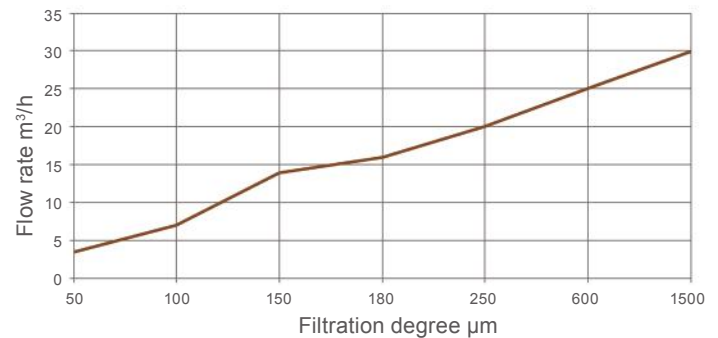

**Descrizione generale**

L'aspetto più caratteristico dei filtri ALSF3/ ASF3 consiste nella grande efficienza di funzionamento dovuto al particolare rapporto fra superficie d'ingresso e superficie filtrante. Inoltre, grazie alla particolare struttura interna, il liquido da filtrare è costretto ad assumere un movimento vorticoso che consente di distribuire le impurità in modo uniforme su tutto l'elemento filtrante portando le particelle solide sul fondo della coppa, garantendo così minori interventi di manutenzione. Il modello ASF3 ha le medesime caratteristiche funzionali dell'equivalente modello ALSF3 in alluminio.

**General description**

The ALSF3/ASF3 filters most particular characteristic consists of their high performing efficiency due to the ratio between the input area and filtering surface. Moreover thanks to the internal structure, the liquid is forced into a swirling movement which distributes the impurities evenly over the whole cartridge bringing the solid particles onto the base of the bowl. It means less maintenance is required as the result of this. The ASF3 type has the same functional characteristics as the equivalent ALSF3 filter aluminium made.

**Descripción general**

El elemento más característico de los filtros ALSF3/ASF3 consiste en su gran eficiencia de funcionamiento, gracias a la particular relación entre la superficie de entrada y la superficie filtrante. Además, a causa de su particular estructura interna, el líquido a filtrar es obligado a asumir un movimiento de torbellino, que distribuye las impurezas en modo uniforme en todo el elemento filtrante, llevando las partículas sólidas hacia el fondo de la copa y reduciendo así las intervenciones de mantenimiento. El modelo ASF3 tiene las mismas características funcionales del equivalente modelo ALSF3 de aluminio.

**Caratteristiche tecniche**
**Technical specifications**
**Características técnicas**

|  |  |
|--|--|
| PRESSIONE D'ESERCIZIO<br>OPERATING PRESSURE<br>PRESIÓN DE FUNCIONAMIENTO                                 | 30 barg  |
| GRADI DI FILTRAZIONE<br>FILTRATION DEGREES<br>GRADOS DE FILTRACIÓN                                       | Da 50 µ in su / From 50 µ onwards / De 50 µ hacia arriba |
| PRESSIONE DI PROGETTO<br>DESIGN PRESSURE<br>PRESIÓN DE PROYECTO  | 45 barg  |
| TEMPERATURA MASSIMA D'ESERCIZIO<br>MAXIMUM OPERATING TEMPERATURE<br>TEMPERATURA MÁXIMA DE FUNCIONAMIENTO | 70°C   |
| FLANGE ENTRATA/USCITA<br>INLET / OUTLET FLANGES<br>BRIDAS ENTRADA/SALIDA                                 | Ø 1 1/2"   |
| SCARICO<br>DISCHARGE<br>DESCARGA   | Ø 3/8"   |
| VALVOLA DI SCARICO<br>DRAIN VALVE<br>VÁLVULA DE DESCARGA   | a sfera manuale / manual ball / de esfera manual         |

Diverse riduzioni per ingresso-uscita a richiesta.

Reductions to different inlet-outlet connections on request.

Reducciones de entrada-salida diferentes sobre pedido.

**Costruzione**
**Filtro in linea ALSF3**

I filtri serie ALSF3 sono realizzati in lega di alluminio bonificato di alta qualità.

**Filtro in linea ASF3**

L'esecuzione in fusione di acciaio inox AISI 316 ne esalta le prestazioni in caso di impieghi con liquidi particolarmente aggressivi o in condizioni di lavoro gravose.

**Materials**
**ALSF3 line filter**

Eurospray ALSF3 series filters are high quality hardened and tempered cast aluminium made.

**ASF3 line filter**

The ASF3 type is cast SS316 stainless steel made and particularly compatible with aggressive liquids or chemicals and for heavy duty.

**Construcción**
**Filtro de linea ALSF3**

Los filtros serie ALSF3 son de aleación de aluminio templado y recocido de elevada calidad.

**Filtro de linea ASF3**

La elaboración de fusión de acero inoxidable AISI 316 incrementa sus prestaciones en caso de utilización con líquidos particularmente agresivos o en condiciones de trabajo gravosas.

**Cartuccia filtrante**

La cartuccia filtrante è in lamiera microstrirata inox con diversi gradi di ritenzione.

**Filter cartridge**

The filter cartridge screen wire or light-perforated stainless steel with various filtering degrees.

**Cartucho filtrante**

El cartucho filtrante es de chapa micro-tensada inox con diferentes grados de retención.

**Portate**

Valori di portata max in m<sup>3</sup>/h con acqua pulita e perdita di carico di 0,2/0,3 barg, con differenti gradi di ritenzione.

**Flow rate**

Maximum flow rates (m<sup>3</sup>/h) values determined with a pressure drop of 0.2-0.3 barg, with different types of filter cartridges.

**Caudales**

Valores de caudal máx. en m<sup>3</sup>/h con agua limpia y pérdida de carga de 0.2/0.3 barg, con diferentes grados de retención.

**FLOW RATE MAX WITH CLEAN WATER**

| TYPE OF FILTER       | Surface area of cartridge (dm <sup>2</sup> ) | 1500 µ<br>10 mesh             | 600 µ<br>30 mesh              | 250 µ<br>60 mesh              | 180 µ<br>80 mesh              | 150 µ<br>100 mesh             | 100 µ<br>150 mesh             | 50 µ<br>400 mesh              |
|----------------------|--|-------------------------------|-------------------------------|-------------------------------|-------------------------------|-------------------------------|-------------------------------|-------------------------------|
|                      |  | flow rate (m <sup>3</sup> /h) | flow rate (m <sup>3</sup> /h) | flow rate (m <sup>3</sup> /h) | flow rate (m <sup>3</sup> /h) | flow rate (m <sup>3</sup> /h) | flow rate (m <sup>3</sup> /h) | flow rate (m <sup>3</sup> /h) |
| ALSF3<br>screen wire | 3,4  | 42                            | 37                            | 34                            | 27                            | 24                            | 16                            | 9                             |
| ASF3<br>screen wire  | 3,4  | 42                            | 37                            | 34                            | 27                            | 24                            | 16                            | 9                             |

## FILTRO IN LINEA ALSF4

### ALSF4 LINE FILTER

### FILTRO DE LINEA ALSF4

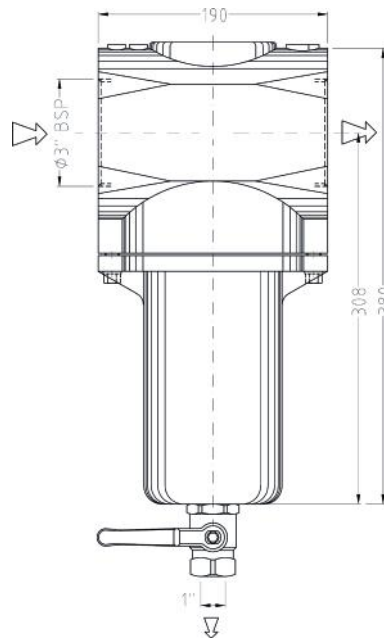

PESO 9 Kg  
 WEIGHT  
 PESO

### Descrizione generale

L'aspetto più caratteristico dei filtri ALSF4 consiste nella grande efficienza di funzionamento dovuto al particolare rapporto fra superficie d'ingresso e superficie filtrante. Inoltre, grazie alla particolare struttura interna, il liquido da filtrare è costretto ad assumere un movimento vorticoso che consente di distribuire le impurità in modo uniforme su tutto l'elemento filtrante portando le particelle solide sul fondo della coppa, garantendo così minori interventi di manutenzione.

### General description

The ALSF4 filters most particular characteristic consists of their high performing efficiency due to the ratio between the input area and filtering surface. Moreover thanks to the internal structure, the liquid is forced into a swirling movement which distributes the impurities evenly over the whole cartridge bringing the solid particles onto the base of the bowl. It means less maintenance is required as the result of this.

### Descripción general

El elemento más característico de los filtros ALSF4 consiste en su gran eficiencia de funcionamiento, gracias a la particular relación entre la superficie de entrada y la superficie filtrante. Además, a causa de su particular estructura interna, el líquido a filtrar es obligado a asumir un movimiento de torbellino, que distribuye las impurezas en modo uniforme en todo el elemento filtrante, llevando las partículas sólidas hacia el fondo de la copa y reduciendo así las intervenciones de mantenimiento.

### Caratteristiche tecniche

### Technical specifications

### Características técnicas

|  |  |
|--|--|
| PRESSIONE D'ESERCIZIO<br>OPERATING PRESSURE<br>PRESIÓN DE FUNCIONAMIENTO                                 | 10 barg  |
| GRADI DI FILTRAZIONE<br>FILTRATION DEGREES<br>GRADOS DE FILTRACIÓN                                       | Da 50 µ in su / From 50 µ onwards / De 50 µ hacia arriba |
| PRESSIONE DI PROGETTO<br>DESIGN PRESSURE<br>PRESIÓN DE PROYECTO  | 15 barg  |
| TEMPERATURA MASSIMA D'ESERCIZIO<br>MAXIMUM OPERATING TEMPERATURE<br>TEMPERATURA MÁXIMA DE FUNCIONAMIENTO | 70°C   |
| FLANGE ENTRATA/USCITA<br>INLET / OUTLET FLANGES<br>BRIDAS ENTRADA/SALIDA                                 | Ø 3"   |
| SCARICO<br>DISCHARGE<br>DESCARGA   | Ø 1"   |
| VALVOLA DI SCARICO<br>DRAIN VALVE<br>VÁLVULA DE DESCARGA   | a sfera manuale / manual ball / de esfera manual         |

**FLOW DIAGRAM WITH 1 GR/LT  
OF SUSPENDED SOLID SCREEN WIRE**

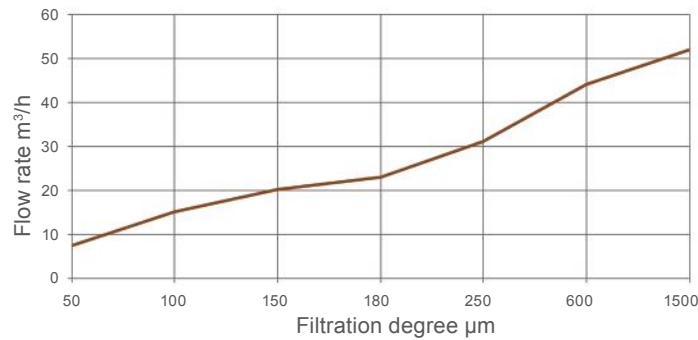
 Data test with H<sub>2</sub>O at 20°C

Diverse riduzioni per ingresso-uscita a richiesta.

*Reductions to different inlet-outlet connections on request.*
*Reducciones de entrada-salida diferentes sobre pedido.*

### Costruzione

I filtri serie ALSF4 sono realizzati in lega di alluminio bonificato di alta qualità.

### Materials

*Eurospray ALSF4 series filters are high quality hardened and tempered cast aluminium made.*

### Construcción

*Los filtros serie ALSF4 son de aleación de aluminio templado y recocido de elevada calidad.*

### Cartuccia filtrante

La cartuccia filtrante è in lamiera microstratata inox con diversi gradi di ritenzione.

### Filter cartridge

*The filter cartridge screen wire or light-perforated stainless steel with various filtering degrees.*

### Cartucho filtrante

*El cartucho filtrante es de chapa microstratada inox con diferentes grados de retención.*

### Portate

Valori di portata max in m³/h con acqua pulita e perdita di carico di 0,2/0,3 barg, con differenti gradi di ritenzione.

### Flow rate

*Maximum flow rates (m³/h) values determined with a pressure drop of 0.2-0.3 barg, with different types of filter cartridges.*

### Caudales

*Valores de caudal máx. en m³/h con agua limpia y pérdida de carga de 0.2/0.3 barg, con diferentes grados de retención.*
**FLOW RATE MAX WITH CLEAN WATER**

| TYPE OF FILTER    | Surface area of cartridge (dm²) | 1500 µ<br>10 mesh | 1000 µ<br>18 mesh | 600 µ<br>30 mesh | 500 µ<br>35 mesh | 400 µ<br>40 mesh | 250 µ<br>60 mesh | 180 µ<br>80 mesh | 150 µ<br>100 mesh | 100 µ<br>150 mesh | 50 µ<br>400 mesh |
|-------------------|---------------------------------|-------------------|-------------------|------------------|------------------|------------------|------------------|------------------|-------------------|-------------------|------------------|
|                   |                                 | flow rate (m³/h)  | flow rate (m³/h)  | flow rate (m³/h) | flow rate (m³/h) | flow rate (m³/h) | flow rate (m³/h) | flow rate (m³/h) | flow rate (m³/h)  | flow rate (m³/h)  | flow rate (m³/h) |
| ALSF4 screen wire | 7                               | 89                |                   | 74               |                  |                  | 42               | 31               | 27                | 22                | 12               |

**FILTRO IN LINEA  
IN PLASTICA SERIE P-SF3/4-5**  
**P-SF3/4-5 PLASTIC LINE FILTER**  
**FILTRO DE LINEA EN PLASTICO  
SERIE P-SF3/4-5**



PESO 0,2 Kg  
WEIGHT  
PESO

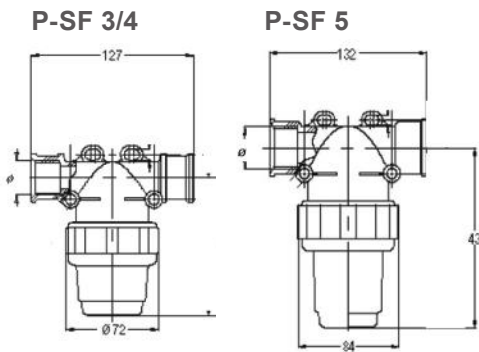

**P-SF 3/4 50MESH**



**P-SF 5 50MESH**

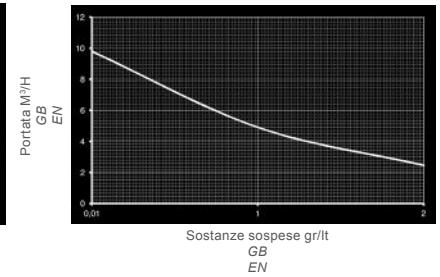

**P-SF 3/4 100MESH**

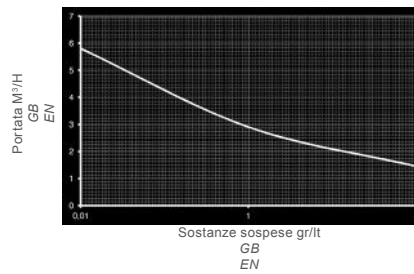

**P-SF 5 100MESH**

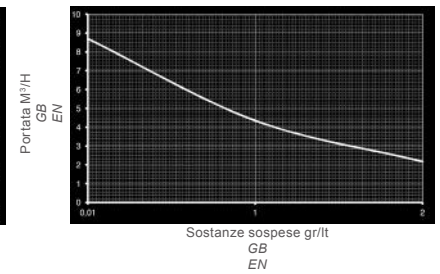

**FILTRO IN LINEA  
IN PLASTICA SERIE P-SF6/7**  
**P-SF6/7 PLASTIC LINE FILTER**  
**FILTRO DE LINEA EN PLASTICO  
SERIE P-SF6/7**



PESO 0,7 Kg  
WEIGHT  
PESO

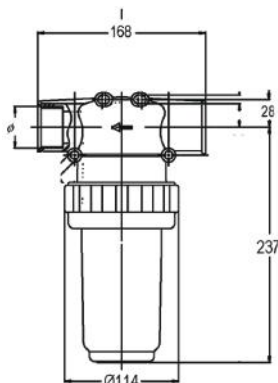

**P-SF 6/7 50MESH**

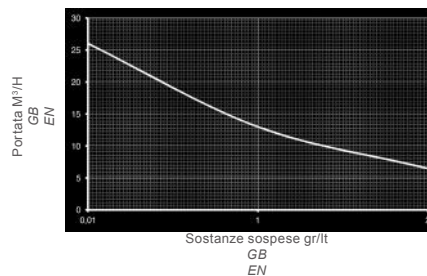

**P-SF 6/7 100MESH**

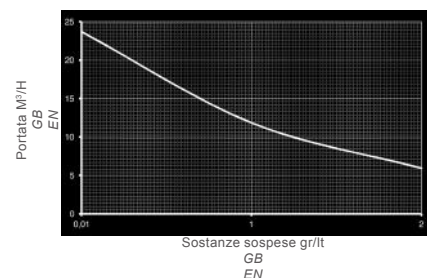



## Descrizione generale

I filtri P-SF in polipropilene vengono comunemente impiegati per risolvere problematiche di filtrazione in linea su impianti dove il costo d'installazione è particolarmente importante; inoltre vengono installati in circuiti con fluidi aggressivi verso l'alluminio e l'acciaio inossidabile (p.e. Candeggina, acido cloridrico, acido bromico ecc.).

## General description

The P-SF filters polypropylene made are commonly used to solve line filtering problems in plants with a particularly low installation costs. In addition they are installed in circuits with fluids that are aggressive towards aluminium and stainless steel ( e.g. bleach, hydrochloric acid, bromic acid, etc. )

## Descripción general

Los filtros P-SF de polipropileno se emplean normalmente para resolver problemas de filtración en línea en las instalaciones donde el costo de instalación es especialmente importante; además, se instalan en circuitos con fluidos agresivos hacia el aluminio y el acero inoxidable (p.e. Lejía, ácido clorhídrico, ácido bromico etc.).

## Caratteristiche tecniche

## Technical specifications

## Características técnicas

|  |   |
|--|---|
| PRESSIONE D'ESERCIZIO<br>OPERATING PRESSURE<br>PRESIÓN DE FUNCIONAMIENTO                                 | P-SF3/4/5 - 20 barg MAX<br>P-SF6/7 - 13 barg MAX  |
| GRADI DI FILTRAZIONE<br>FILTRATION DEGREES<br>GRADOS DE FILTRACIÓN                                       | Da 150 µ a 600 µ / From 150 µ to 600 µ / De 150 µ hacia 600 µ   |
| PRESSIONE DI PROGETTO<br>DESIGN PRESSURE<br>PRESIÓN DE PROYECTO  | P-SF3/4/5 - 18 barg<br>P-SF6/7 - 22 barg  |
| TEMPERATURA MASSIMA D'ESERCIZIO<br>MAXIMUM OPERATING TEMPERATURE<br>TEMPERATURA MÁXIMA DE FUNCIONAMIENTO | 70°C  |
| FLANGE ENTRATA/USCITA<br>INLET / OUTLET FLANGES<br>BRIDAS ENTRADA/SALIDA                                 | P-SF3/4/5 - Ø 1/2" - 3/4" - 1" femmina / female / hembra<br>P-SF6/7 - Ø 1 1/4" - 1 1/2" femmina / female / hembra |

## Costruzione

L'esecuzione in plastica stampata consente di ottenere notevoli economie di prezzo senza prescindere dalle prestazioni di portata e pressione.

## Materials

The moulded plastic execution ensure a very effective spare in price without compromising filters high performance in terms of flow rate and pressure.

## Construcción

La ejecución en plástico estampado permite obtener notables economías de precio sin tener en cuenta las prestaciones de caudal y presión.

## Cartuccia filtrante

La cartuccia filtrante è in rete inox. Sono disponibili le seguenti filtrazioni:  
 - 32 mesh (600 µ) - 50 mesh (300 µ)  
 - 80 mesh (180 µ) - 100 mesh (150 µ)

## Filter cartridge

Filter cartridge is stainless steel wire screen mesh in a choice of following features:  
 - 32 mesh (600 µ) - 50 mesh (300 µ)  
 - 80 mesh (180 µ) - 100 mesh (150 µ)

## Cartucho filtrante

El cartucho filtrante es de malla inox. Están disponibles las siguientes filtraciones:  
 - 32 mesh (600 µ) - 50 mesh (300 µ)  
 - 80 mesh (180 µ) - 100 mesh (150 µ)

## Portate

Valori di portata max in m<sup>3</sup>/h con acqua pulita con alcuni tipici gradi di ritenzione (50 e 100 mesh): in ordinate la perdita di carico corrispondente.

## Flow rate

Maximum flow rates (m<sup>3</sup>/h) values with clean water and some typical retention degrees (50 and 100 mesh): see the corresponding pressure drop on the Y axis.

## Caudales

Valores de caudal máx. en m<sup>3</sup>/h con agua limpia con algunos típicos grados de retención (50 y 100 mesh): en ordenadas la pérdida de carga correspondiente.



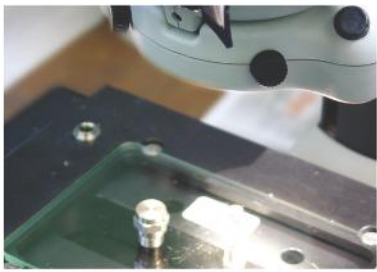

**euspray**<sup>®</sup>  
by Eurospray spray and filter technology SL

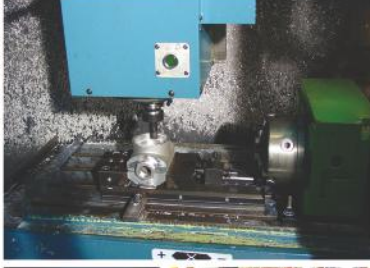
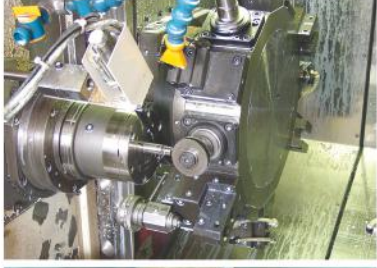

**euspray**<sup>®</sup>  
by Eurospray spray and filter technology SL

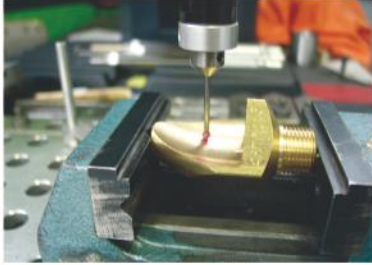

**euspray**<sup>®</sup>  
by Eurospray spray and filter technology SL

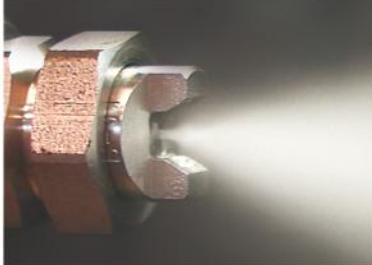

We are present in the following Countries



Eurospray  
Northern Europe LTD  
Chester UK

Australia  
Austria  
Chile  
Egypt  
France  
Germany  
Greece  
India  
Indonesia  
Ireland  
Italy  
Lituania  
Poland  
Czech Republic  
Russia  
Singapore  
Slovakia  
South Africa  
Turkey  
Ukraine



Eurospray  
Spray and Filter  
Technology SL  
E. Conata I  
c/ Fructuós Gelabert, 2-4 - 6°2ªA  
08970 Sant Joan Despí  
(Barcelona) ES

Technical Service:  
info@euspray.com  
infotech@euspray.com

Sales Service:  
export@euspray.com

Customer Service:

Free Phone  
00800 230 220 10

[www.euspray.com](http://www.euspray.com)